

# TIGER HOOK™ ©2004 AMCOE INC.

PIN	PARTS SIDE	SOLDER SIDE	PIN
1	VIDEO RED	VIDEO GREEN	1
2	VIDEO BLUE	VIDEO SYNC	2
3	SPEAKER +	SPEAKER -	3
4	EXTRA - STOP 1		4
5	EXTRA - STOP 2	EXTRA - ALL STOP	5
6	EXTRA - STOP 3		6
7	TICKET OUT BUTTON - panel		7
8	TICKET NOTCH - dispenser		8
9	<b>START / TAKE</b>		9
10	<b>STOP 2 / SMALL (SHARED)</b>		10
11	<b>PLAY</b>		11
12	<b>STOP 3 / TAKE (SHARED)</b>		12
13	<b>STOP 1 / DOUBLE (SHARED)</b>		13
14			14
15			15
16	<b>ALL STOP / BIG (SHARED)</b>		16
17			17
18	COIN IN	NOTE IN	18
19	SERVICE IN		19
20	ACCOUNT / PRINTER SET UP	CONFIRM / MONITOR SET UP	20
21	HOPPER PAYOUT - panel	CLEAR / PRINTER PRINT - panel	21
22		*HOPPER SWITCH - hopper	22
23	COIN IN METER		23
24	NOTE IN METER		24
25			25
26			26
27	HOPPER METER		27
28	CLEAR / TICKET / PRINTER METER		28
29	<b>START / TAKE LAMP</b>	EXTRA - ALL STOP LAMP	29
30	<b>STOP 2 / SMALL LAMP (SHARED)</b>	EXTRA - STOP 1 LAMP	30
31	<b>PLAY LAMP</b>	EXTRA - STOP 2 LAMP	31
32	<b>STOP 3 / TAKE LAMP (SHARED)</b>	EXTRA - STOP 3 LAMP	32
33	<b>STOP 1 / DOUBLE LAMP (SHARED)</b>		33
34	<b>ALL STOP / BIG LAMP (SHARED)</b>		34
35			35
36	GND	GND	36

PIN	PARTS SIDE	SOLDER SIDE	PIN
1	GND	GND	1
2	GND	GND	2
3	+5V	+5V	3
4	+5V	+5V	4
5	+12V	+12V	5
6	+12V	+12V	6
7	TICKET DISPENSER ENABLE		7
8	HOPPER SSR		8
9	GND	GND	9
10	GND	GND	10

\* HOPPER SWITCH - auto detect normal low (mostly micro switch type) or normal high (mostly sensor type)  
 SHADED PIN OUTS ARE NOT AVAILABLE IN LIMIT WIN VERSION  
 STOP BUTTONS: SELECT SHARED BUTTON OR EXTRA BUTTON CONFIGURATION.

# TIGER HOOK™ ©2004 AMCOE INC.

## New S2000C board

The new S2000C board is a powerful platform designed to give sophisticated performance, special visual effects, finer resolutions, communication capabilities, and to make it a more cost-effective investment.

There are 3 communication ports on the board. The RS232 port is primarily used to drive printer to print tickets without any interface. It can also be used to download / upload data and instructions from / to PC. To drive a printer to print ticket, simply connect with a 25 pin one-to-one straight through cable to the serial port of the printer. Printer ticket set up can be done on screen (or download from PC - SEE MANUAL OF PC DOWNLOAD). Go to Account Screen and follow instructions. The following printer settings have to be adjusted on the printer: BAUD RATE = 9600, WORD LENGTH = 8 BITS, PARITY = NO. Also, SW1 next to the RS232 port has to be set correctly (see other pages of this manual).

The other 2 communication ports (using RJ45 connectors) are mainly for linking with other S2000 / S2000C boards or Link Control Unit.

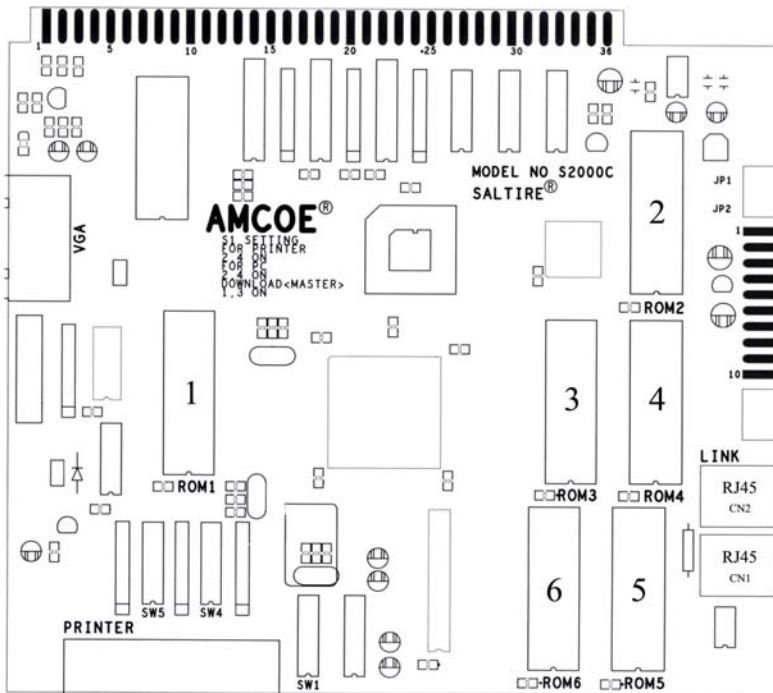

Application such as linking progressive bonus of all the machines together to display on screen in real time can be done efficiently (see manual of LINK). CAT5 patch cables are used. To connect with S2000 board or Link Control Unit with older type 3 pin connector (not RJ45), a small connection interface board is available.

S2000C platform is also capable of driving VGA high-resolution monitor with VGA program ROMs and certain components added / changed on the board. With VGA mode game, a VGA connector will be present on the board with necessary components added / changed. There is no need to connect video signals from the edge connector. (VGA mode game is an independently designed game and is not a version of a CGA mode game. Thus, games available in standard CGA mode will not be available in VGA mode.)

**S2000C is password protected.** Password is ***user defined***. It must be 6 digits. There is no toggle switch for reset on the board. Reset is divided into two parts, either reset both Adjustment and Data or Data only. Certain situations require reset action, such as after change of program or program error. Password is needed to reset and to change on screen adjustments. User Password, Power On count, In Meter and Out Meter will not be reset. In Meter and Out Meter are 6 digits, working exactly the same as mechanical ones.

### MONITOR ADJUSTMENT (CGA mode)

The resolutions of S2000C are 33.3% more than that of New Cherry '96. Sync, V-size, V-pos, H-pos,...etc. may have to be adjusted. After reset or existing Confirm Screen, a test screen (similar to left shown) will come up.

1/ Dip SW 5 # 1 - "OFF" Korean made (most USA brands) monitor; "ON" Taiwanese made.

2/ Adjust Sync of monitor to get a stable picture.

3/ Adjust V-size, V-pos, H-size, and H-pos such that all 4 white corner brackets (right-angled shape) can be seen and are a little bit away from the curving edges of the monitor.

4/ Adjust color purity. Most monitors may look fine without further adjusting colors, but a re-adjustment will make sure true color representations, not only for the S2000C board

but for all other games. There are 4 color bands, a gray & white card, and 4 white corner brackets on the test screen. The 4 color bands are (pure) red, green, blue, and white. Turn brightness on until background is no longer "black" and turn RGB to the lowest. Turn G up until flare comes out (like a shadow going outside the edge) on white; then, reduce gradually until the flare "just" disappears. Do the same thing with R and B one by one. Lastly, reduce brightness until background is "black". There are 4 fine tuning adjustments of horizontal and vertical positions using the software of the program. See on screen instruction.

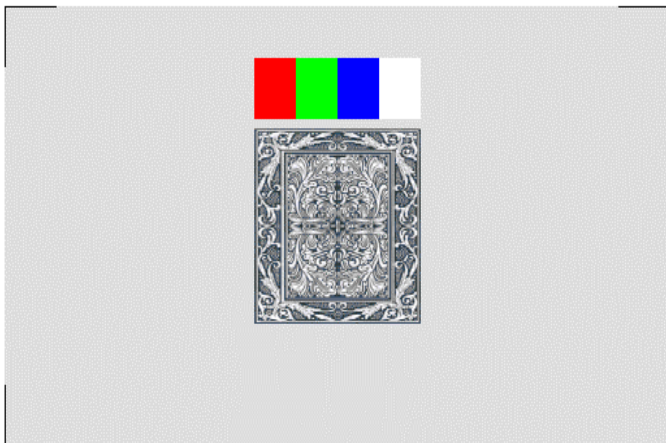

# TIGER HOOK™ ©2004 AMCOE INC.

DIP SW 5		1	2	3	4	5	6	7	8
MONITOR TYPE	KOREAN MADE TAIWANESE MADE	OFF ON	For most monitors used in USA						
UNIT ID SETUP FOR PROGRESSIVE LINK BONUS Each Unit in the Link System must has a unique ID. Monitor used must has an <u>isolation transformer or built-            in isolation circuit.</u> Two or more units having the same ID or monitor without an isolation transformer will DAMAGE the board. (Link Control Unit and CAT5 patch cable required. To connect with older type 3 pin link connector, a small connector interface board is required. Just one is needed in the entire link system.)	NO LINK		OFF	OFF	OFF	OFF			
	UNIT 1		ON	OFF	OFF	OFF			
	UNIT 2		OFF	ON	OFF	OFF			
	UNIT 3		ON	ON	OFF	OFF			
	UNIT 4		OFF	OFF	ON	OFF			
	UNIT 5		ON	OFF	ON	OFF			
	UNIT 6		OFF	ON	ON	ON			
	UNIT 7		ON	ON	ON	OFF			
	UNIT 8		OFF	OFF	OFF	ON			
	UNIT 9		ON	OFF	OFF	ON			
	UNIT 10		OFF	ON	OFF	ON			
	UNIT 11		ON	ON	OFF	ON			
	UNIT 12		OFF	OFF	ON	ON			
	UNIT 13		ON	OFF	ON	ON			
	UNIT 14		OFF	ON	ON	ON			
UNIT 15		ON	ON	ON	ON				
NO USE	MUST BE								OFF

All selections are made on screen or by PC DOWNLOAD except those listed in Dip SW 5. **NOTE: Dip Switch 4 MUST BE OFF.**

Please go to Confirm Screen and following on screen instructions to adjust available selections. Different versions may have different available selections and selectable ranges. Check Confirm Screen and make necessary adjustment to suit your operation.

Selections that can be adjusted on screen (**NOT** for all versions) are as follow:

**LEVEL OF DIFFICULTY:** Default is Level 6.

**COIN IN TO POINT:** It relates to 36 pin edge connector part side 18. 1 pulse in = ? (Only 5 and 25 in LIMIT WIN Version. See Page 4.)

**NOTE IN TO POINT:** It relates to 36 pin edge connector solder side 18. 1 pulse in = ?

**COIN IN LIMIT:** Set the COIN IN limit.

**MIN PLAY TO START:** Min point(s) required to start to play a game.

**MIN PLAY FOR BONUS:** Min points required in order to get bonus features.

**MAX PLAY:** Max points which can be played in a game.

**BONUS 1 BASE:** The starting bonus point of Bonus 1 at PLAY=240. Automatically calculate according to PLAY during game play.

**BONUS 1 MAX:** The maximum bonus point of Bonus 1 at PLAY=240. Automatically calculate according to PLAY during game play.

**BONUS 2 BASE:** The starting bonus point of Bonus 2 at PLAY=240. Automatically calculate according to PLAY during game play.

**BONUS 2 MAX:** The maximum bonus point of Bonus 2 at PLAY=240. Automatically calculate according to PLAY during game play.

**BONUS ACCUMULATE:** YES (progressive from Base to Max), NO (fixed at Max).

**FIXED BONUS 3:** Fixed bonus point at PLAY=240. Automatically calculate according to PLAY during game play.

**BONUS 3 PERCENT:** Four selections.

**CLEAR / TICKET UNIT:** It relates to 36 pin edge connector part side 28. Each pulse out = ? Point(s).

**TICKET MODE:** It relates to above and regulates max ? pulse(s) out each game. Continuous = no limit.

**TICKET OUT:** It can be Printer Direct\*, Ticket Dispenser Direct Drive (TDDD), or Interface.

**PRINTER TYPE:** Use one central printer via Link Control Unit (VIA LINK) or individual printer installed in machine (USE SELF).

**PRINTER COMMAND:** CBM1 (Citizen) (default), ESC/POS (Epson), STAR emulation, Ithaca 70.

**HOPPER UNIT USE:** Use COIN IN or CLEAR / TICKET UNIT as reference.

**CHANGE PASSWORD:** Select YES when you want to change User Defined Password. Factory Default = 123456

**USE SCORE:** If yes, "SCORE" will appear on screen. All points won will be collected to "SCORE". Default = NO.

**SCORE OUT:** Manual (default) or Auto.

**LIMIT SCORE PER GAME:** Limit SCORE per game play to 10xplay or an equivalent of \$5 whichever is less. (Use LW Version instead.)

**PLAY REMAIN SCORE:** Only when "SCORE" appears on screen. Play directly from "SCORE" when no point left in POINT column.

**COUNT GAME:** This is an advanced count game feature counting eligible pulses out based on TICKET MODE.

**SHOW ACCOUNT:** If no, there is no account information on Account Screen.

**WITHOUT ODDS TABLE:** Show odds table on screen or not. YES = do not show; NO = show.

**STOP BUTTONS:** SHARED BUTTON or EXTRA BUTTON.

**SKILL SPIN:** A non-stop spinning condition and manual stop is mandatory.

**REEL SPEED:** NORMAL or SLOW (default).

**DOUBLE GAME:** YES (default) or NO.

**WIN LIMIT:** Default = \$5 & 10X (check whichever is less) or \$5 ONLY (do not check 10X). (Available in LIMIT WIN VERSION program only.)

Additional selections not mentioned here may be available in some versions.

**CAUTION: Factory is unable to retrieve your User Defined Password. You must remember it yourself.**

**WARNING: DO NOT PUT IN PROGRAM ROM THAT IS NOT DESIGNED FOR THIS GAME.**

\* When using Printer Direct, please go to Account Screen then Printer Ticket Set Up. Remember to do Printer Ticket Set Up again after reset of board!

SHADED ADJUSTMENT SELECTIONS ARE NOT AVAILABLE IN LIMIT WIN VERSION.

Access the Link Control Unit (the program of the Link Control Unit must be Version 1.9 or newer): When in LINK, go to Account Screen. Press ACCOUNT button once will go to a download page. Account information of the entire Link System will be downloaded to the screen. After viewing, follow instruction on screen to (1) erase the recent record inside the Link Control Unit, if wanted to, or (2) exit .

# TIGER HOOK™ ©2004 AMCOE INC.

\*PRINTER: BAUD RATE = 9600, WORD LENGTH = 8 BITS, PARITY = NO.  
 (Dip SW settings of Citizen iDP3540/3541 = DS1 # 1,8 ON; DS2 # 2,5,6,7 ON. Check the manual of printer for correct settings.)  
 (The alarm light of 3550/3551 has to be ON all the time in order to print. 3540/3541/3550/3551 alarm light can be ON all the time)

SW 1	RS232	1	2	3	4	5	6	7	8
Model S2000C	DRIVE PRINTER PC DOWNLOAD	OFF	ON	OFF	ON	OFF	OFF	OFF	OFF

In Printer Ticket Set Up, there are 3 entries that need to be done carefully. (Others are mainly text messages.)

**POINT VALUE:** It is the \$ value of each point. Immediately after reset, program will detect coin in setting and use the following COIN MODE table to assign the \$ value of each point. It can be changed when not using LIMIT SCORE.

**TICKET LIMIT:** Default is \$00.00, meaning no limit. The maximum \$ value of a single ticket can be limited from \$1 to \$99. (CAUTION: do not set TICKET LIMIT-except \$00.00-less than POINT VALUE.)

**PRINT \$ or POINT on ticket:** Select between DOLLAR and POINTS (default).

**Adjust Ticket Setting and Game Setting by PC DOWNLOAD**

S2000C PC DOWNLOAD PROGRAM is distributed FREE. It runs on PC with Windows 95/98. You may obtain a free copy on a 3.5" disk or by downloading it from the internet\*. A HELP file will come up the first time you use it after installation. You will find all necessary information on how to adjust BOTH Ticket Setting and Game Setting of your board by PC. PC Download Program will be especially useful in printer ticket set up. Typing name, address, machine number,...etc. will be much faster on a computer than through on screen input. On your S2000C board, go to Account Screen and press <DOUBLE> to go to PC download mode. Also, remember to set Dip SW S1 (near the RS232 port) of the board to PC download mode during PC download. Press <TAKE> to exit PC download mode.

\* <http://www.amcoe.com>

COIN MODE	COIN IN SETTING	BILL ACCEPTOR SELECTION		\$1 = ? POINTS	LIMIT SCORE
		\$1 = 1 PULSE	\$1 = 4 PULSES		MAX \$5 = ? POINTS
\$1 = 1 PT.	1	YES		1	DO NOT USE
\$0.50 = 1 PT.	2	YES		2	10
\$0.25 = 1 PT.	1		YES	4	20
	4	YES			
\$0.10 = 1 PT.	10	YES		10	50
\$0.05 = 1 PT.	5		YES	20	100
	20	YES			
\$0.01 = 1 PT.	25		YES	100	500
	100	YES			

**Ticket Dispenser Connection Diagram**

DL-1275 (verify pinouts on manual of ticket dispenser)

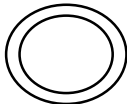
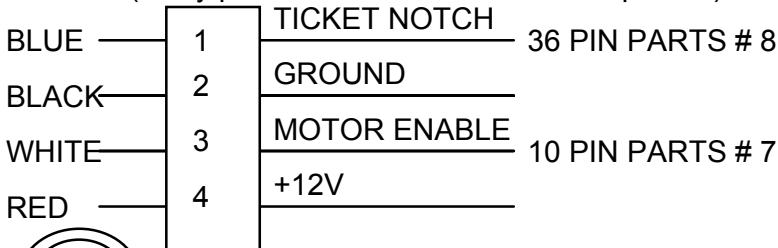

TICKET OUT BUTTON on control panel connect to 36 PIN PARTS # 7

**Hopper Connection Diagram**

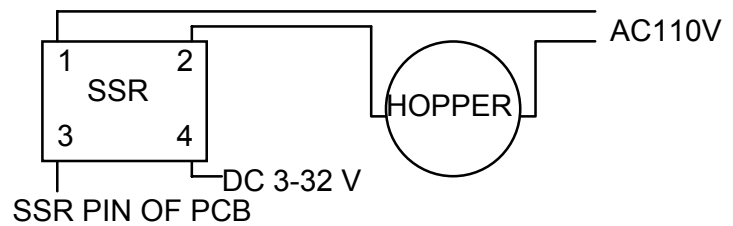

## **TIGER HOOK™** ©2004 AMCOE INC.

TIGER HOOK is an eight line game with 2 progressive bonuses, 1 fixed bonus, 2 animated bonus games, 4 free spin games, 1 animated double game, and 2 exchange symbols in main game.

Progressive Bonus 1: All mixed SHIP, CANNON and TREASURE CHEST. Bonus point varies with PLAY besides gradual accumulation (if Bonus Accumulation = YES).

Progressive Bonus 2: Three TIGER HOOK in a line. Bonus point varies with PLAY besides gradual accumulation (if Bonus Accumulation = YES).

Fixed Bonus 3: Both Line 4 and Line 5 = CHERRY-CHERRY-CHERRY, like an " X " configuration. Bonus point varies with PLAY.

Animated Bonus Game 1: In this game, you have 3 chances to climb up the mast of a ship and avoid being hit by shells firing from the left. Each successful climb to the top without being hit will give you Total Play x 10, thus a total of Total Play x 30 can be obtained. In order to get into Animated Bonus Game 1, you must hit a line of SHIP-SHIP-SHIP in the Main Game.

Animated Bonus Game 2: In this game, you have 3 chances to fire a cannon to hit a distant moving ship. Each hit will give you Total Play x 10, thus a total of Total Play x 30 can be obtained. In order to get into Animated Bonus Game 2, you must hit a line of CANNON-CANNON-CANNON in the Main Game.

Free Spin Game: In the Main Game, each ANYBAR-ANYBAR-ANYBAR line will get 5 Free Spin Games; each BAR1-BAR1-BAR1 line will get 7 Free Spin Games; each BAR2-BAR2-BAR2 line will get 9 Free Spin Games; each BAR3-BAR3-BAR3 line will get 11 Free Spin Games.

In Free Spin Game, one or more "X2" symbol(s) may come out. Whatever win normally will time the total number of "X2". For example: If the normal win is 1000 points and there are three "X2" symbols appeared, the actual win will be  $1000 \times 2 \times 3$  (number of "X2") = 6000.

Animated Double Game: It is quite simple and straightforward. Just choose between two treasure chests. One will contain treasure, meaning win; another will have a skeleton pop up, meaning loss.

Exchange Symbols in Main Game (and in Free Spin Game):

TIGER HOOK: When TIGER HOOK comes up and there is no winning combination with it, it will change to another symbol.

CANNON: When CANNON comes up and there is no winning combination with it, it will change to another symbol.

The exchange of symbol is *to improve* the chance of winning. It is not an artificial effect that intends to please and fool the player. Thus, not each exchange of symbol will yield additional winning combination and whatever additional winning combination created is indeed *a real improvement to the original outcome*.

LINK BONUS: Link with other S2000 and S2000C series games. All Mixed BAR is reserved for hitting the LINK BONUS. See the manual of LINK as well.

# TIGER HOOK™ ©2004 AMCOE INC.

## PUSH BUTTON LEGEND

<b>ALL STOP</b> <b>BIG</b>	<b>STOP 1</b> <b>DOUBLE</b>	<b>STOP 2</b> <b>SMALL</b>	<b>STOP 3</b> <b>TAKE</b>
-------------------------------	--------------------------------	-------------------------------	------------------------------

<b>TAKE</b> <b>START</b>	<b>PLAY</b>
-----------------------------	-------------

START BUTTON ALSO ACTS AS TAKE BUTTON

<b>ALL STOP</b> <b>BIG</b>	<b>STOP 1</b> <b>DOUBLE</b>	<b>STOP 2</b> <b>SMALL</b>	<b>STOP 3</b> <b>TAKE</b>
-------------------------------	--------------------------------	-------------------------------	------------------------------

<b>PLAY</b>	<b>TAKE</b> <b>START</b>
-------------	-----------------------------

SHARED BUTTON CONFIGURATION

<b>TAKE</b> <b>START</b>	<b>ALL STOP</b>	<b>STOP 1</b>	<b>STOP 2</b>	<b>STOP 3</b>
-----------------------------	-----------------	---------------	---------------	---------------

<b>PLAY</b>	<b>BIG</b>	<b>DOUBLE</b>	<b>SMALL</b>	<b>TAKE</b>
-------------	------------	---------------	--------------	-------------

START BUTTON ALSO ACTS AS TAKE BUTTON

<b>TAKE</b> <b>START</b>	<b>ALL STOP</b>	<b>STOP 1</b>	<b>STOP 2</b>	<b>STOP 3</b>
-----------------------------	-----------------	---------------	---------------	---------------

<b>PLAY</b>	<b>BIG</b>	<b>DOUBLE</b>	<b>SMALL</b>	<b>TAKE</b>
-------------	------------	---------------	--------------	-------------

EXTRA BUTTON CONFIGURATION