

TREASURE CITY (Treasure Island – Part IV)

INTRODUCTION

(Version 1.52M)

BONUS (JACKPOT)

The Bonus value is displayed on the upper left corner of the screen in a split window. The upper value progresses 1 credit per 80 credits played; the lower, 1 credit per 120 credits played with a base value of 1000. The Upper value is awarded when five “crown 7s” cross at center screen (bet lines 1 & 7.) The lower value is then transferred to the upper window and becomes the available bonus.

	7	
7	7	7
	7	

DIAMOND FEVER

This bonus is awarded when play results in a line of blue, green or red diamonds. The value of the diamond fever bonus is determined by a pool player who continues to hit numbered balls until a “skull” ball is hit once for blue diamonds, twice for green and three times for red diamonds. The total bet is multiplied by the ball numbers to determine the bonus value.

CASH FEVER

This bonus is awarded for each line of “5 Dollar Bills.” The player hits “START” to drop a parachutist from a plane. The parachutist lands on one of a stream of numbered cars as they pass under the plane. Award is the total bet times the number on the car that the parachutist lands on. Maximum award is 40 times bet. Multiple lines of “5 Dollar Bills” result in multiple parachutists dropping.

CROSS BELL

This award is a progressive pool. Each line of “Bells” awards the total bet to the pool. The pool is awarded when five “bells” cross at center screen (bet line 1 & 7.) The base is determined by past betting pattern.

DOUBLE-UP

A standard Big-Small double up with cards set in a tavern. Lots of action behind the dealer.

DIRECT DRIVE TICKET DISPENSER

Direct Drive Ticket Dispenser allows control of ticket value and number of tickets per game without use of an interface board. Use of Auto Dispense mode collects all points won in a separate “SCORE” section until value equals “Clear Ticket Unit.” With “Play Score” enabled player can use score points to bet only when CREDITS is zero.

OPERATION GUIDE

A) BOOK

- 1) Press the BOOK key to show the book screens. Press again for next page (3 pages.)
- 2) First page for the data of IN/OUT & Play Record. Second and third pages are for the Winning frequency of prizes.
- 3) Press the START key to return to the main game.

B) RESET (Clear)

a) Clear ALL

- 1) Turn on the machine, push the RESET button on board to clear all data.
- 2) The Main Game rate & Double-Up Rate should be cleared by this function.
- 3) In the first page of the BOOK, there are four uncleared counters related to Coin, Payout, Keyin and Keyout which aren't affected by this function. Those screens counters are to compare relatively with four machines each time you collect.
- 4) THIS function doesn't work when the power is OFF.

b) Clear the data of COIN, PAYOUT, KEYIN and KEYOUT only

- 1) Press the BOOK key to display the first page of BOOK which includes the data of COIN, PAYOUT, KEYIN and KEYOUT.
- 2) Press the RESET button on the board to clear the data of IN and OUT for the above.
- 3) Except for IN/OUT data, Win Rate and other data remain unchanged by this function.

C) TEST – New Feature

- 1) Press the TEST key one time to display the status of the DIP switches.
- 2) This screen will display the DIP switch settings for confirmation purposes. You can change a switch on the board and it will immediately show the change on the screen.
- 3) Press the START key to return to the main game. DIP adjustments should be changed automatically and made instantly available.
- 4) PLEASE NOTE: After changing Main Game Rate, we strongly recommend you reset the board. If you don't, the Main Game Rate will be unstable.
- 5) Press the TEST key twice to display the SYSTEM TEST screen. This screen is only for testing and not for making adjustments. PLEASE NOTE: You have to turn off the power to leave this screen.

D) OTHER

- 1) Remember to push RESET button if you change Main Game Rate.
- 2) Don't adjust voltage while the board is turned on.
- 3) Please turn off the power before changing the EPROM.

CONNECTOR TREASURE CITY (USA)

COMPONENT Side A	36 PIN	SOLDER Side B
Video RED	1	Video GREEN
Video BLUE	2	Video SYNC.
Speaker (+)	3	Speaker (-)
	4	
	5	
	6	
Ticket OUT Button	7	
Ticket NOTCH	8	
START Button	9	
SMALL Button	10	
BET Button	11	
TAKE Button	12	
DOUBLE Button	13	
	14	
	15	
BIG Button	16	
	17	
Coin IN (Coin A)	18	KeyIN (Coin B)
	19	
BOOK Button	20	Test Button
Pay OUT Button	21	KeyOUT Switch
	22	Hopper Switch
Coin IN Counter	23	
KeyIN Counter	24	
	25	
	26	
PayOUT Counter	27	
Ticket Counter	28	
Start Lamp	29	
Big Lamp	30	Small Lamp
Bet Lamp	31	
Take Lamp	32	
Double Lamp	33	
	34	
	35	
GND	36	GND

COMPONENT Side A	36 Pin	SOLDER Side B
GND	1	GND
GND	2	GND
+5V	3	+5V
+5V	4	+5V
+12V	5	+12V
	6	
TICKET ENABLE	7	
	8	
GND	9	GND
GND	10	GND

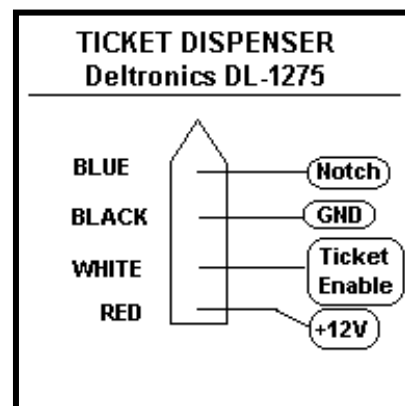
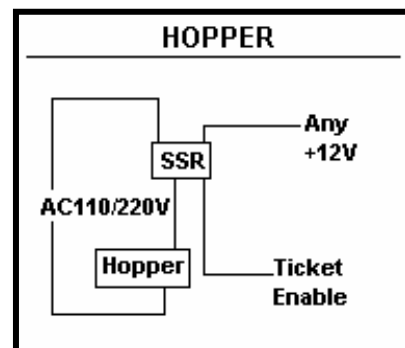

- Please check manual of Ticket Dispenser for wire colors before connecting.
- For Hoppers, Please connect Hopper Pay Button to 36 pin connector, pin 21 Part Side.

Treasure City ver 1.52 – will control the number of tickets per spin independent from auto ticket dispense. Therefore, it can be set to work with a ticket out button but still it will limit the number of tickets per game. If you want the ticket out button to work as a knock-off switch, simply set the ticket out limit to continuous. This version also incorporates a hold pair feature that allows up to two pairs to be held using TAKE and BIG buttons. The final change to this version adds MAX BET 10 and 50.

DIP SW.1		1	2	3	4	5	6	7	8
1 Coin	1 Credit	OFF	OFF	OFF					
1 Coin	5 Credit	ON	OFF	OFF					
1 Coin	10 Credits	OFF	ON	OFF					
1 Coin	20 Credits	ON	ON	OFF					
1 Coin	25 Credits	OFF	OFF	ON					
1 Coin	50 Credits	ON	OFF	ON					
1 Coin	100 Credits	OFF	ON	ON					
1 Coin	500 Credits	ON	ON	ON					
1 Keyin	1 Credit				OFF	OFF	OFF		
1 Keyin	5 Credits				ON	OFF	OFF		
1 Keyin	10 Credits				OFF	ON	OFF		
1 Keyin	20 Credits				ON	ON	OFF		
1 Keyin	25 Credits				OFF	OFF	ON		
1 Keyin	50 Credits				ON	OFF	ON		
1 Keyin	100 Credits				OFF	ON	ON		
1 Keyin	500 Credits				ON	ON	ON		
Keyin Payout								OFF	
Coin Payout								ON	
Panel Type A								OFF	
Panel Type B								ON	

DIP SW. 2		1	2	3	4	5	6	7	8
Min. Bet	1	ON	OFF						
	8	OFF	OFF						
	10	ON	ON						
	16	OFF	ON						
Max. Bet	10			ON	OFF				
	16			OFF	ON				
	50			OFF	OFF				
	120			ON	ON				
Reel Speed	Fast					OFF			
	Slow					ON			
Play Score (Auto ticket) (When Credit=0)	OFF					OFF			
	ON					ON			
Demo Music	Enable						ON		
	Disable						OFF		
Double-Up	Disable	* Auto Take Score						ON	
	Enable							OFF	

DIP SW. 3		1	2	3	4	5	6	7	8
Main Game Rate	96%	ON	ON	ON	85%		Payout Rate		
	95%	OFF	ON	ON	80%				
	94%	OFF	OFF	OFF	75%				
	93%	ON	OFF	ON	70%				
	92%	OFF	OFF	ON	65%				
	91%	ON	ON	OFF	60%				
	90%	OFF	ON	OFF	55%				
	89%	ON	OFF	OFF	50%				
Game Limit	10,000				ON	OFF			
	20,000				OFF	OFF			
	60,000				OFF	ON			
	100,000				ON	ON			
Auto Ticket Dispense						OFF			
						ON			
Ticket out Limit	None						OFF	OFF	
	10						ON	OFF	
	5						OFF	ON	
	1						ON	ON	

