

# Bill Acceptor

## Installation/Operation Guide



MARS ELECTRONICS INTERNATIONAL

Bill Acceptor/\$1, \$5, \$10, \$20 Acceptance with Stacker

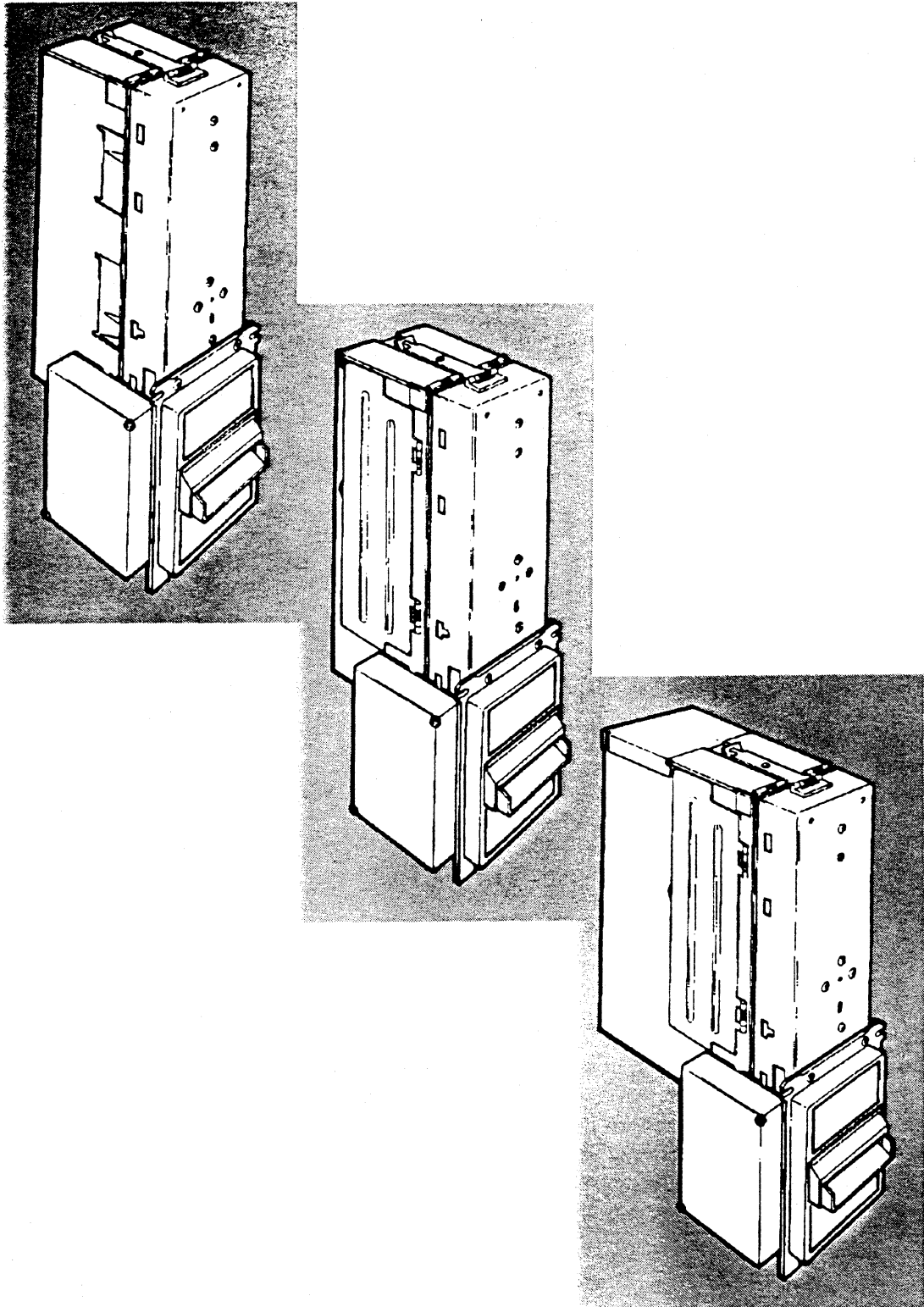

## CONTENTS

<b>GENERAL INFORMATION</b>	<b>p. 1</b>
<b>OPTION SWITCH SETTING</b>	<b>p. 2</b>
<b>BILL ACCEPTOR INSTALLATION</b>	<b>p. 4</b>
<b>CHECKOUT PROCEDURE</b>	<b>p. 7</b>
<b>LOCKOUT</b>	<b>p. 8</b>
<b>MAINTENANCE</b>	<b>p. 10</b>
<b>CONNECTOR INFORMATION</b>	<b>p. 17</b>

## GENERAL INFORMATION

The MARS ELECTRONICS® Bill Acceptor (Fig. 1) is designed for use as a stand-alone unit. The unit is capable of operating via one of two interfaces: Pulse Interface or Serial Interface. The following instruction describes the Pulse Interface. For information about the Serial Interface, contact Mars Electronics for interface specifications.

### Power Requirements

117VAC bill acceptors --  
 1 amp @ 95-135 VAC  
 24VAC bill acceptors --  
 4.5 amp @ 22.0-32.1 VAC

*(Note: Amperage given indicates fuse requirement.)*

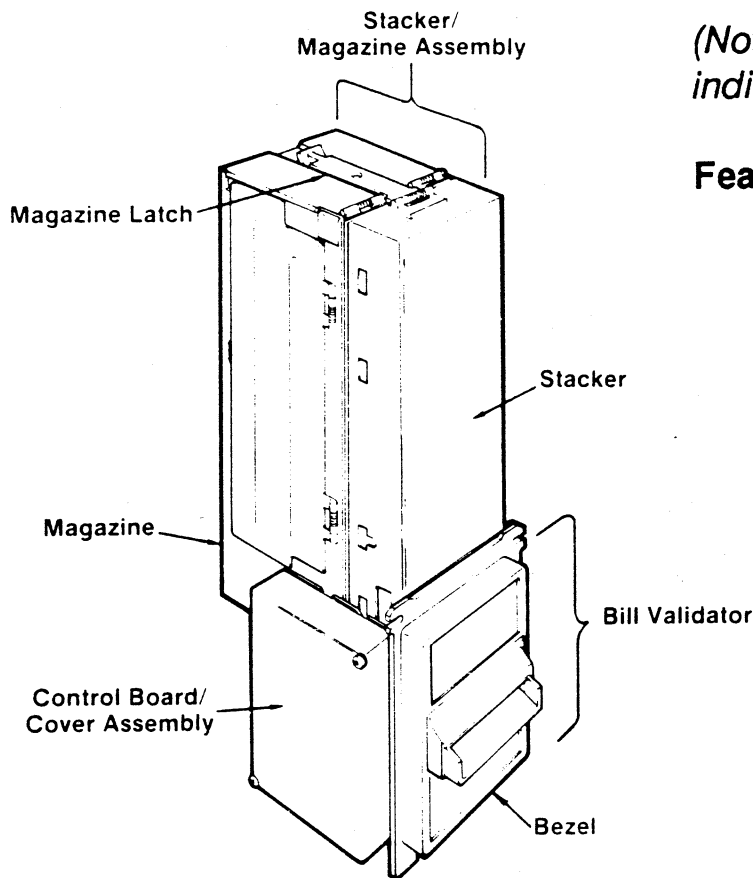

### Features

- Selective acceptance of \$1, \$5, \$10, and/or \$20 bills
- 1 to 4 credit pulses per dollar credit
- Easy lockout for amusement applications (no money accepted while game is in play)
- Adaptable for new and retrofit applications

MARS ELECTRONICS® Bill Acceptor

FIGURE 1

**BEFORE INSTALLING AND OPERATING BILL ACCEPTOR, CHECK OPTION SWITCH SETTINGS.**

## OPTION SWITCH SETTINGS

---

**Prior to mounting the bill acceptor or connecting the harness, check option switch settings as follows:**

### SETTING THE OPTION SWITCHES

Remove the Control Board/Cover Assembly and set switches with a retracted ball point pen or a small screwdriver (Fig. 2). Do not use a graphite pencil point.

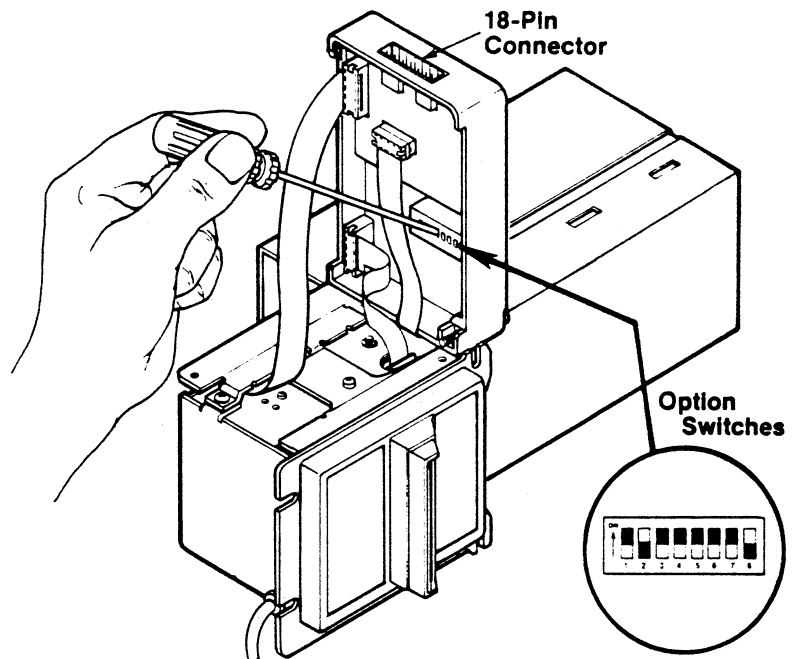

Setting the Option Switches

FIGURE 2

### OPTION SWITCH FEATURES

Figure 3 details switch functions and provides a sample switch setting.

Option Switch #2 allows for differences in coin input circuits in various machines. While this switch is normally set in the OFF position for a fast pulse, it can be set in the ON position if slower pulses are required.

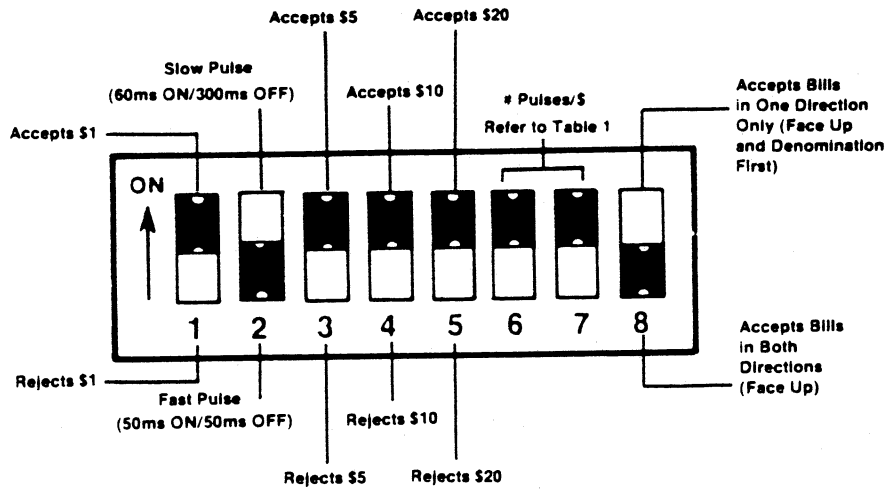

Switch Functions and Sample Switch Setting

FIGURE 3

### CREDIT PULSES

The number of pulses per dollar credit is determined by the combined setting of Option Switches #6 and #7. (Refer to Table 1.) When the bill acceptor is installed in a machine with a 25¢ price, these pulses can be considered quarter equivalents. In such applications, a switch setting that produces four quarter pulses per dollar may be desirable.

A \$1 bill produces the set number of pulses. A \$5 bill produces five times the number of pulses, and so on.

**Example:** For 4 credit pulses per dollar, Switches 6 and 7 must be ON.

TABLE 1: PULSES PER DOLLAR CREDIT

<u>Switch #6</u>	<u>Switch #7</u>	<u># of Pulses/Dollar</u>
OFF	OFF	1
ON	OFF	2
OFF	ON	3
ON	ON	4

## BILL ACCEPTOR INSTALLATION

*Note: For amusement applications, a kit (#91-16-245-4) is available that provides a wiring harness, 18-pin connector, and mounting hardware. This kit is only for use with 117VAC bill acceptors.)*

### Step 1: Connect Harnesses

Connect the appropriate harness to the 9-pin connector of the bill acceptor (Fig. 4).

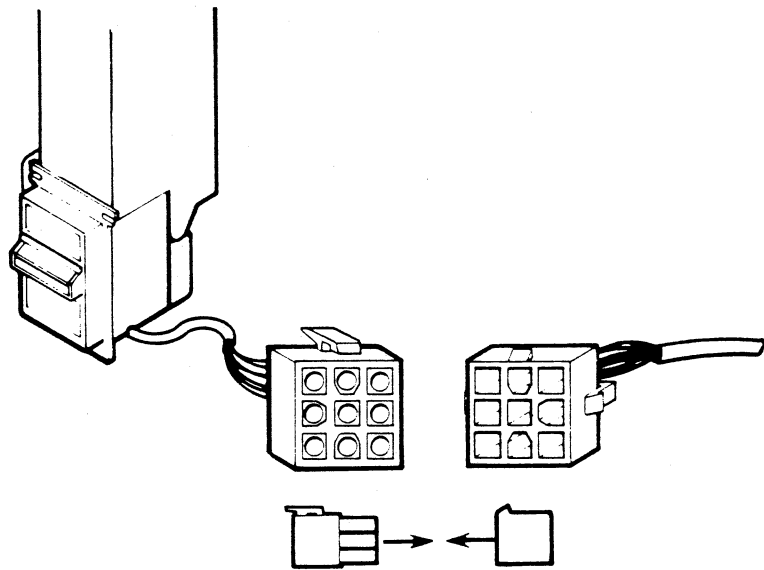

Seating the 9-Pin Connector  
FIGURE 4

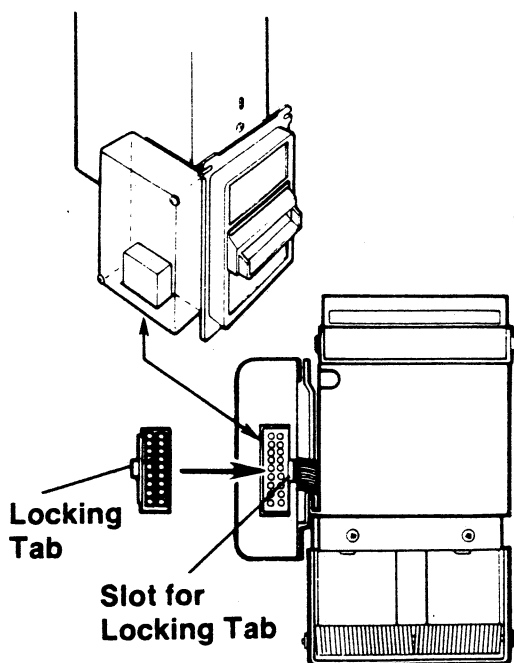

Seating the 18-Pin Connector  
FIGURE 5

Install the black, 18-pin in-line connector into the bottom of the Control Board/Cover Assembly (Fig. 5). Be sure to properly orient the locking tab.

## Step 2: Mount Bill Acceptor

Disconnect A.C. power from the machine and mount the bill acceptor. Make sure to allow for sufficient room to accommodate the height and depth of the stacker (Fig. 6)

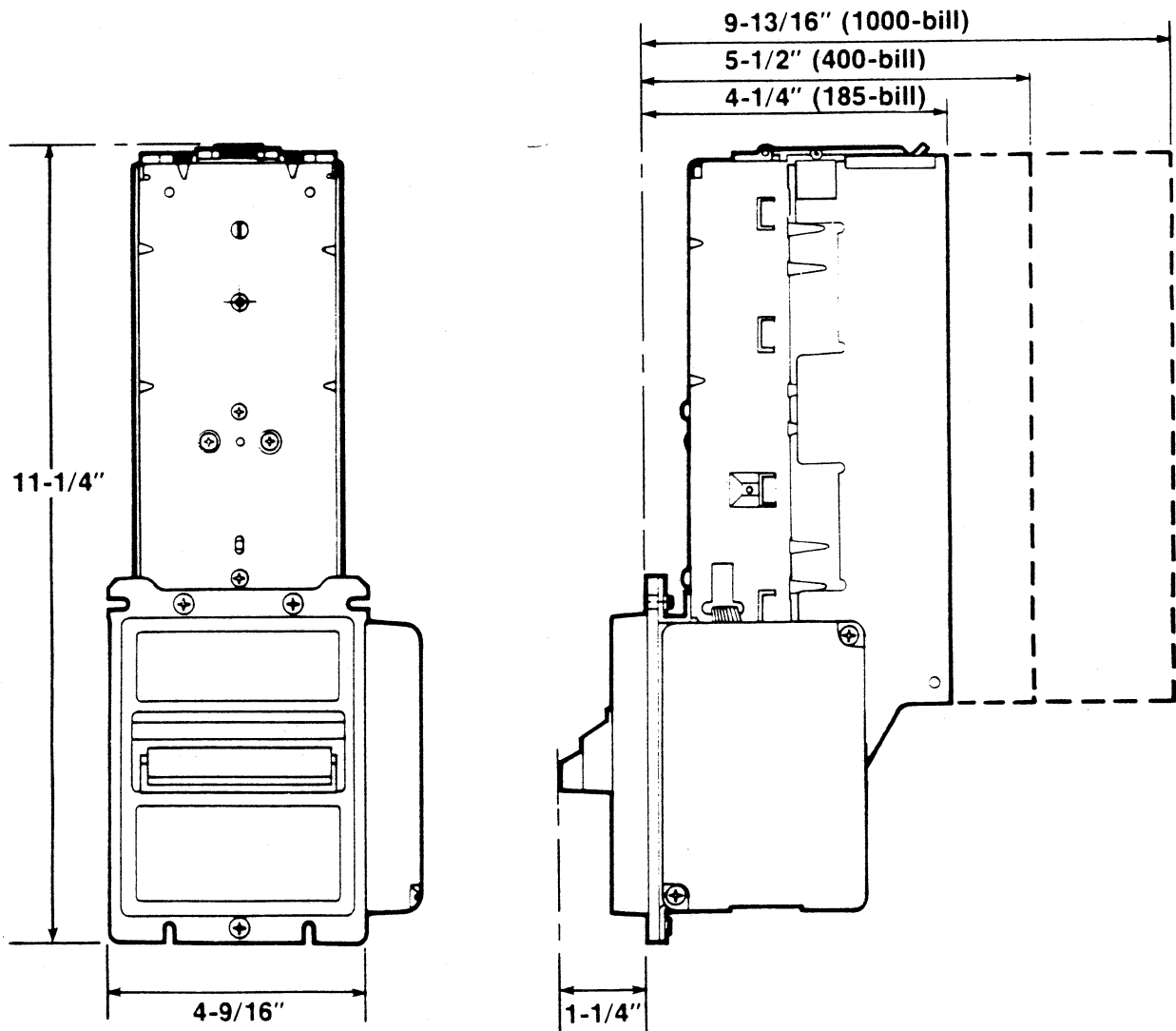

Bill Acceptor Dimensions  
FIGURE 6

### Step 3: Install Harness

With one end already connected to the bill acceptor, route the wiring harness through the machine and make the necessary connections. Dress all harness wires to avoid interference with machine operation.

### Step 4: Test

The installation is now complete. Apply power and test for proper operation as described in "Checkout Procedure."

### Step 5: Remove Bills

To remove bills from the Magazine (Fig. 7), open the assembly by releasing the magazine latch. Remove bills through the top (all bill acceptors) or side (400- and 1,000-bill magazines) panels.

*Note: Do not remove bills from inside the bill acceptor by pressing down on the pressure plate. This can damage the Magazine.*

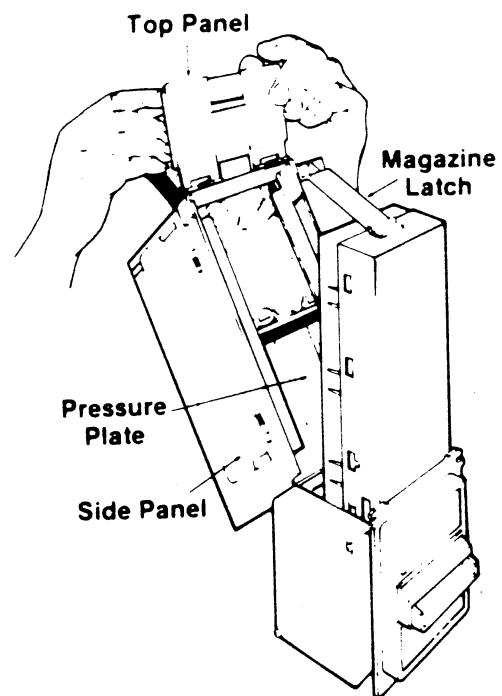

Removing Bills from the Magazine  
FIGURE 7

---

## CHECKOUT PROCEDURE

---

- Insert several bills of each accepted denomination into the unit. The bills should be accepted and the correct number of pulses produced. (Remember that a \$5 bill will produce five times the number of pulses as a \$1 bill, etc.)
- Insert bills black (portrait) side up. Bills should be accepted in one or both directions as selected with Option Switch #8. Insert bills green side up; they should be rejected.
- Some machines are unable to accept the number of pulses produced by \$5, \$10, and \$20 bills. Test by inserting a bill of each denomination accepted and observing that the correct number of credits is displayed on the machine. If not, set Switches 3, 4, and 5 OFF to reject these bills. (Refer to Figure 3.)
- Some machines can accept pulses at a faster rate than others. If the unit is missing pulses, the pulse setting may be too fast for that particular machine. Setting Option Switch #2 in the ON position for a slow pulse rate should correct the problem.

---

## LOCKOUT (Inhibiting Acceptance)

---

### Features

Certain games do not allow money to be credited while the game is in play. Lockout is an optional procedure that prevents insertion of bills at times when the game cannot accept credits.

*Note: The following instructions refer to an 18-pin connector; this is supplied in Installation Kit #91-16-245.*

### Wiring Connections

For Normal Operation (as supplied in kit -- unit accepts money at any time):

Pin 3  
Pin 4  
Pin 12     connected at wire nut  
Pin 14

For Lockout Feature (controlled acceptance of money -- refer to Fig. 8):

Leave Pin 3 connected to  
Pin 4 at wire nut  
Leave Pin 4 connected to wire nut  
Cut wire to Pin 12

- connect half from connector to machine lockout signal
- connect half from wire nut to machine logic ground

Leave Pin 14 connected to  
Pin 4 at wire nut.

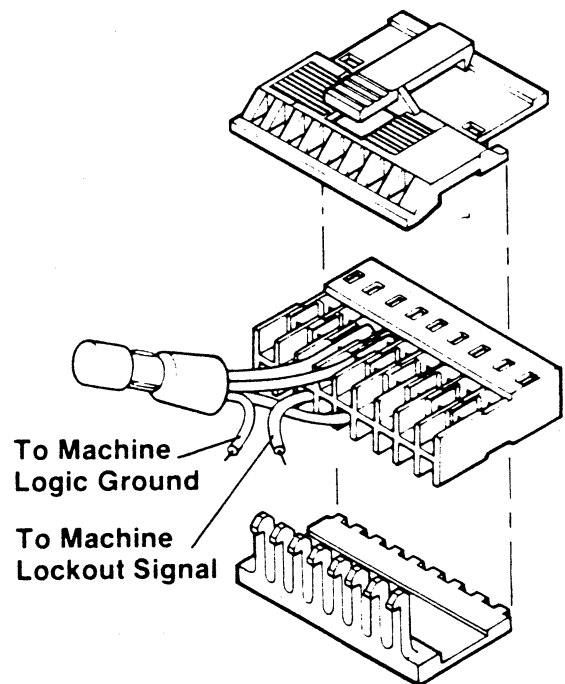

Options Available on 18-Pin Connector  
Figure 8

Lockout is achieved by controlling the voltage on Pin 12 of the 18-pin connector. To enable lockout, tie the system logic ground\* to Pin 4 of the 18-pin connector by way of the wire nut. Connect the machine lockout signal to Pin 12. When Pin 12 is low, the bill acceptor will accept monies. If Pin 12 is high, or open, acceptance is inhibited.

If the source of voltage to Pin 12 exceeds +5 volts DC, the bill acceptor draws current from the source as limited by the 1k pullup to 5v and the internal breakdown diode of the integrated circuit (IC). To prevent damage to the IC, a series diode (IN4148 or equiv.) may be connected (Fig. 9) with its anode to Pin 12. This prevents current from flowing into the bill acceptor. The input IC is a CMOS/TTL compatible device.

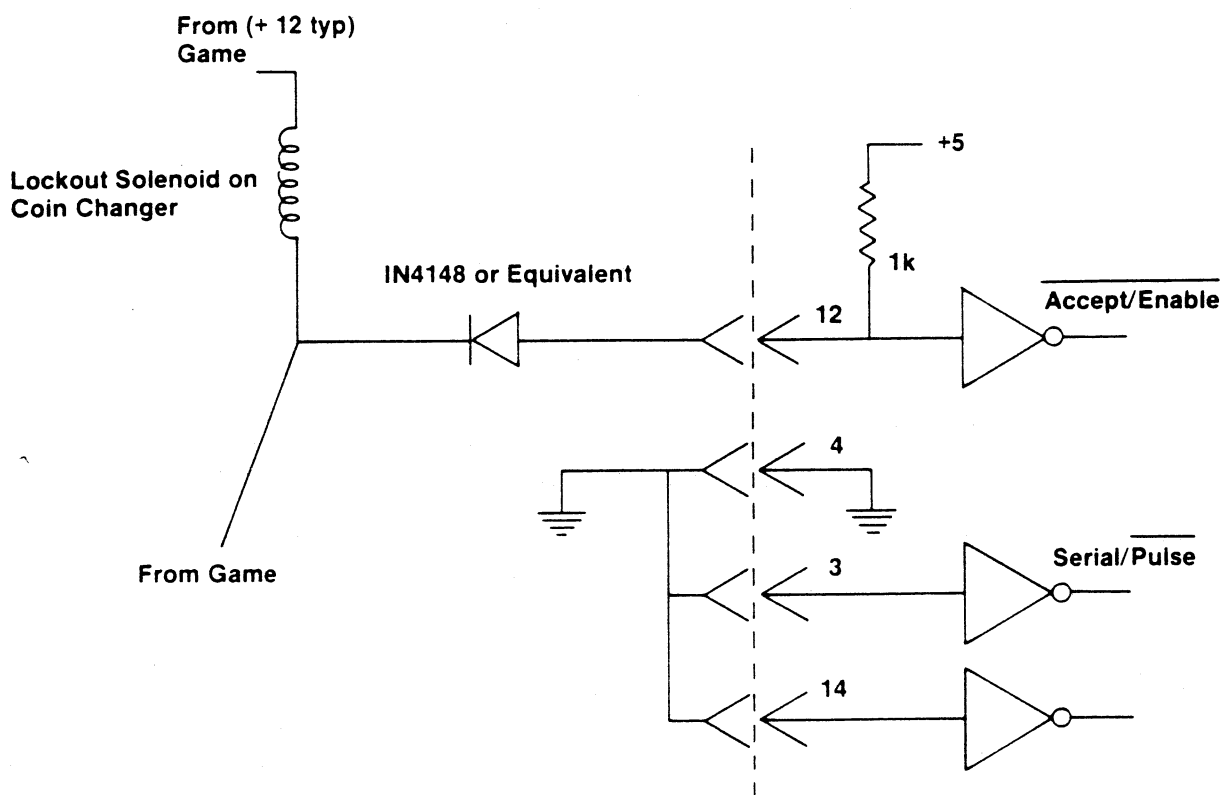

\* Note that logic ground and power ground must not be connected.

Lockout Diagram  
FIGURE 9

---

---

## MAINTENANCE

---

---

Trapped bills/debris can result in poor bill acceptance or bill rejection. To clear jams and clean the bill acceptor, refer to the following instructions.

### CLEARING JAMS

Jam conditions can occur in two portions of the bill acceptor -- the Stacker/Magazine Assembly and the Bill Validator. When looking for the source of the jam, always examine the Stacker/Magazine Assembly first. This avoids unnecessary disassembly of the bill acceptor.

#### Clearing Jams in the Stacker/Magazine Assembly

##### *Step 1: Open Magazine*

For 185-bill magazines, check for jams by releasing the magazine latch and opening the Stacker/Magazine Assembly and/or top panel. For 400- or 1000-bill magazines, open the side and/or top panels or, if space permits, open the assembly (Fig. 10).

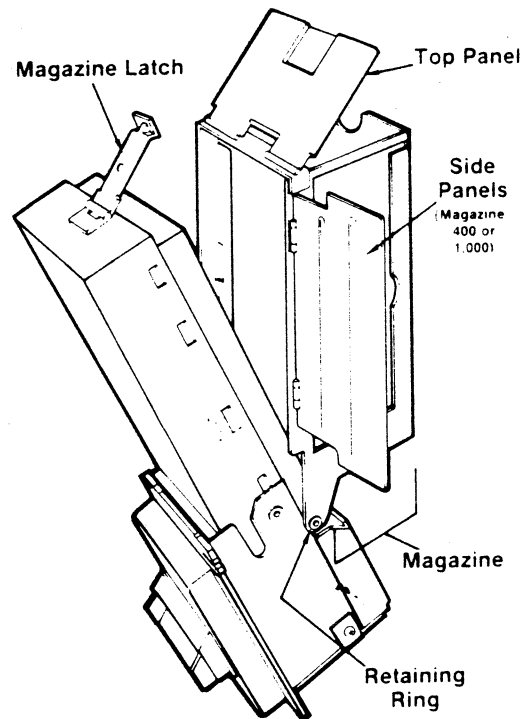

Opening the Stacker/ Magazine Assembly

FIGURE 10

##### *Step 2: Dislodge Jam*

If the jammed bill or debris is visible, attempt to remove it with your fingers or tweezers. Most jams can be cleared by this method. If it is not possible to remove the material in this manner, proceed to the next section.

## Clearing Jams in the Bill Validator

To clear jams in the Bill Validator portion of the bill acceptor, disassemble the unit as follows:

### *Step 1: Remove Bill Acceptor from Machine*

Disconnect the bill acceptor from the power source. Remove it from the vending machine.

### *Step 2: Remove Bezel*

Remove the three flathead screws (A) from the face of the bill acceptor Bezel (Fig. 11). Remove the Bezel.

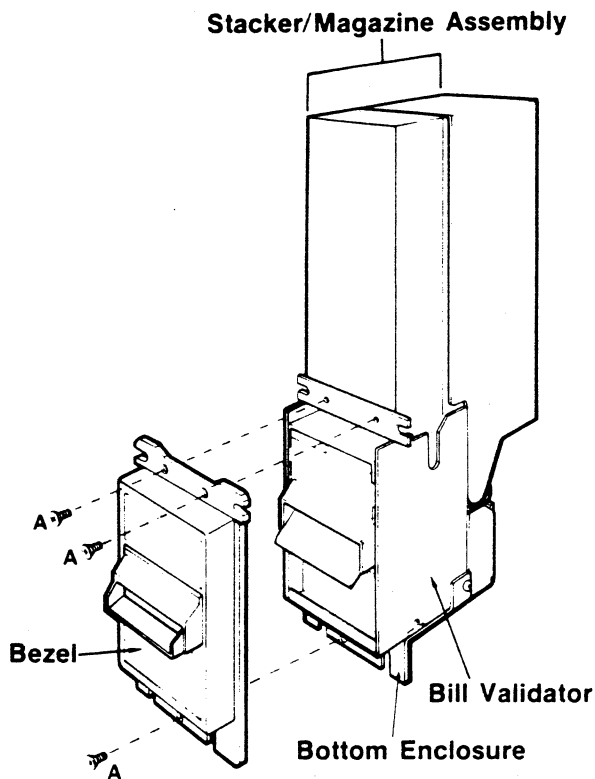

Removing the Bezel

FIGURE 11

### *Step 3: Remove Control Board/Cover Assembly*

Loosen the captive screws (B) of the Control Board/Cover Assembly (Fig. 12). Pull the assembly away from the bill acceptor.

Disconnect the three harnesses from the Control Board. Remove the Control Board/Cover Assembly, along with its insulator (if installed).

**Step 4: Determine Bill Acceptor Model**

Refer to the bill acceptor model number:

- if the model number ends in "S", skip to Step 6.
- for other models, remove the Control Board Mounting Plate as described in Step 5.

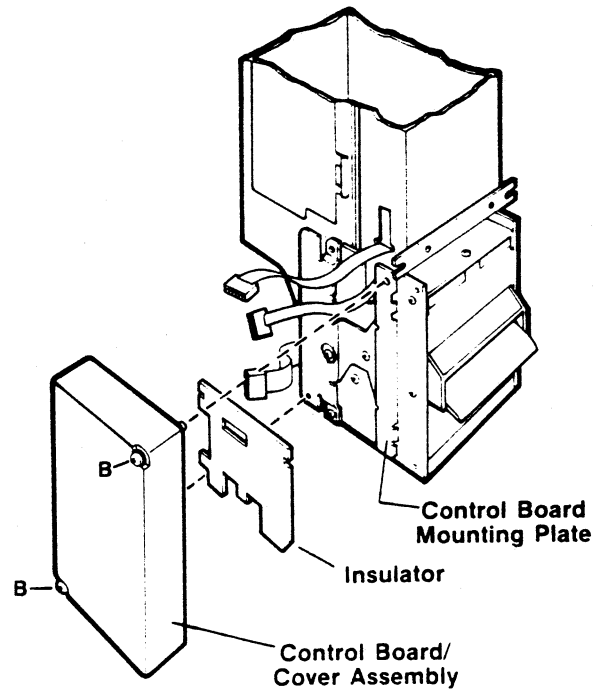

Removing the Control Board/Cover Assembly  
FIGURE 12

**Step 5: Remove Control Board Mounting Plate**

Remove screws (C) and (D), as indicated, to detach the Control Board Mounting Plate (Fig. 13). Remove washer behind screw C. The screws that hold the Bill Validator to the Stacker/Magazine Assembly are now accessible.

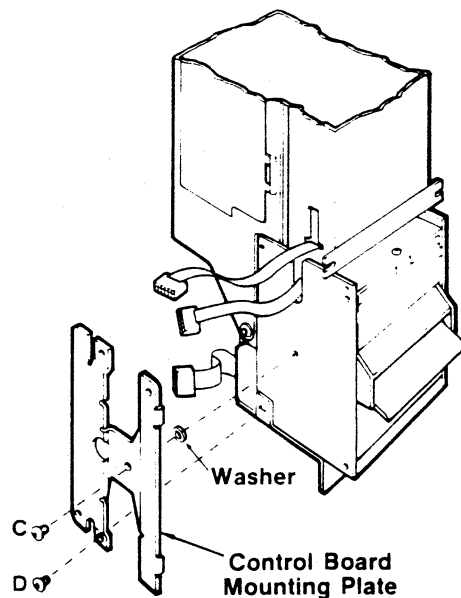

Detaching the Control Board Mounting Plate  
FIGURE 13

### Step 6: Separate the Bill Validator from the Stacker/Magazine Assembly

Remove the two screws (F), as indicated (Fig. 14), that hold the Bill Validator to the Stacker/Magazine Assembly.

Grasp the Bill Validator portion of the bill acceptor in one hand and the Stacker in the other. Slide the Bill Validator forward and away from the Stacker until the two separate.

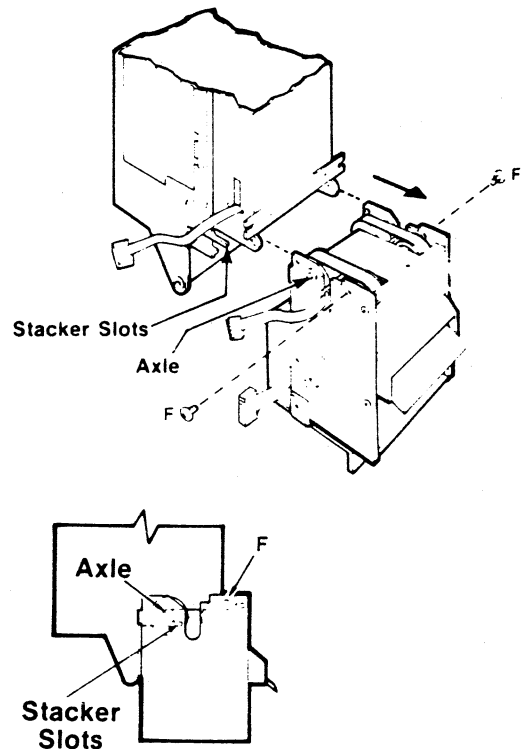

Separating the Bill Validator from the Stacker/Magazine Assembly

FIGURE 14

### Step 7: Open Bill Validator

Remove the screws (G) that hold the Bill Validator closed (Fig. 15).

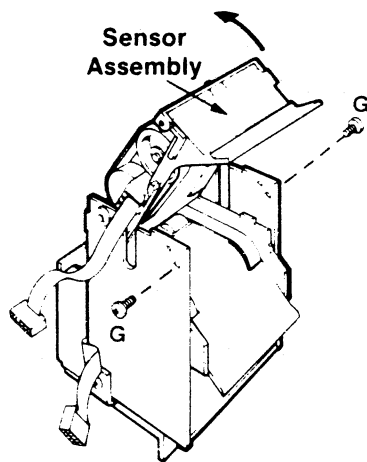

Opening the Bill Validator

FIGURE 15

### Step 8: Dislodge Jam

To clear jams in the Bill Validator:

- lift up the Sensor Assembly to expose the belt area (Fig. 15).
- remove any debris trapped in Credit Lever or Pinch Roller (Fig. 16).

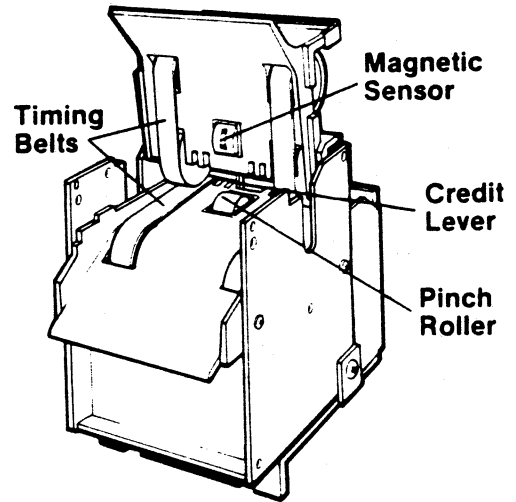

Interior of Bill Validator  
FIGURE 16

## CLEANING THE BILL VALIDATOR

To clean the Bill Validator, refer to the disassembly procedures described in "Clearing Jams in the Bill Validator."

### Step 1: Clean Bill Path

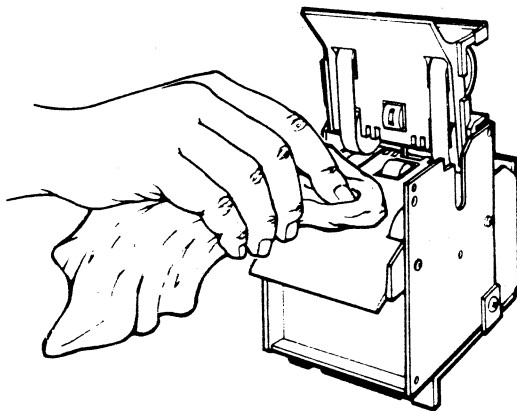

Cleaning the Bill Validator  
FIGURE 17

Lift up the Sensor Assembly (Fig. 15). Clean the bill path plastic and timing belts with a cloth moistened with a mild household cleaner (Fig. 17).

### Step 2: Clean Pinch Roller

Remove debris from the Pinch Roller and Magnetic Sensor using household transparent tape.

### **Step 3: Check Credit Lever**

Check that the Credit Lever is free by fully depressing it several times using a small screwdriver. It should spring back into place without sticking. If the lever does not operate properly, return the unit to Mars Electronics or a Mars Electronics Authorized Service Center for repair.

## **REASSEMBLING THE BILL ACCEPTOR**

### **Step 1: Close Bill Validator**

Lower the Sensor Assembly to close the Bill Validator.

Replace screws (G) in the sides of the Bill Validator (Fig. 15).

*Note: Replace screws carefully to avoid stripping.*

### **Step 2: Attach Stacker/Magazine Assembly to Bill Validator**

Slide the Stacker/Magazine Assembly into the rear of the Bill Validator. Align the stacker slots over the validator axles on both sides (Fig. 14).

Replace the screws (F) that hold the Bill Validator to the Stacker/Magazine Assembly (Fig. 14).

### **Step 3: Replace Control Board Mounting Plate**

Refer to the bill acceptor model number:

- if the model number ends in "S," skip to Step 4.
- for other models, replace the Control Board Mounting Plate using screws (C) and (D) (Fig. 13).

*Note: Screw (D) also fastens one side of the Bottom Enclosure.*

## Step 4: Install Control Board/Cover Assembly

Properly position the insulator, if installed, in the Control Board/Cover Assembly, then seat the head board, stacker, and bill validator harnesses (Fig. 18). Orient the blue polarizing wire on each harness as illustrated.

*Note: Care must be taken to properly install the bill validator harness.*

Dress the harnesses, then replace the Control Board/Cover Assembly (Fig. 12) by tightening the two captive screws.

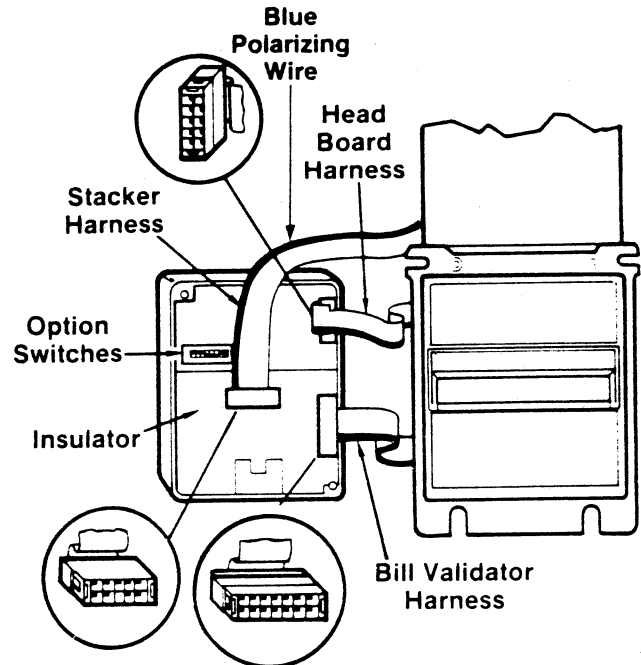

Seating the Bill Validator Harnesses  
FIGURE 18

## Step 5: Replace Bezel

Replace the Bezel (Fig. 11) using the three flathead screws (A).

## Step 6: Check Operation

Reinstall the bill acceptor and check for proper operation. If the unit still does not function properly, return it to Mars Electronics or a Mars Electronics Authorized Service Center for repair.

---

**CONNECTOR INFORMATION**

---

**PULSE INTERFACE**

*Note: Bold type indicates those connections required for Pulse Interface to operate.*

**PINOUT OF 18-PIN CONNECTOR (Fig. 19)**

Pin 1	<b>\$1 CREDIT (Optional – can be used instead of Relay on 9-Pin Connector)</b>	Pin 10	<b>OUT-OF-SERVICE</b>
Pin 2	<i>Reserved</i>	Pin 11	<i>Reserved</i>
<b>Pin 3</b>	<b>SERIAL/PULSE SELECT</b>	<b>Pin 12</b>	<b>ACCEPT ENABLE</b>
<b>Pin 4</b>	<b>GROUND</b>	Pin 13	<b>OUT-OF-SERVICE (LED Power Source)</b>
Pin 5	<i>Reserved</i>	Pin 14	<i>SEND (Optional)</i>
Pin 6	<i>Reserved</i>	Pin 15	<i>Reserved</i>
Pin 7	<i>Reserved</i>	Pin 16	<i>Reserved</i>
Pin 8	<i>Reserved</i>	Pin 17	<i>Reserved</i>
Pin 9	<i>Reserved</i>	Pin 18	<i>Reserved</i>

**PINOUT OF 9-PIN CONNECTOR (Fig. 20)**

	<u>117VAC</u>	<u>24VAC</u>
Pin 1	<i>Reserved</i>	<i>Reserved</i>
Pin 2	<i>Reserved</i>	<i>Reserved</i>
Pin 3	<i>Reserved</i>	<i>Reserved</i>
<b>Pin 4</b>	<b>117VAC HOT (Power)</b>	<i>Reserved</i>
Pin 5	<i>Reserved</i>	<b>24VAC HOT (Power)</b>
<b>Pin 6</b>	<b>117VAC NEUTRAL(Power)</b>	<b>24VAC NEUTRAL (Power)</b>
<b>Pin 7</b>	<b>CREDIT RELAY (Normally Open)</b>	<b>CREDIT RELAY (Normally Open)</b>
Pin 8	<b>CREDIT RELAY (Common)</b>	<b>CREDIT RELAY (Common)</b>
Pin 9	<i>Reserved</i>	<i>Reserved</i>

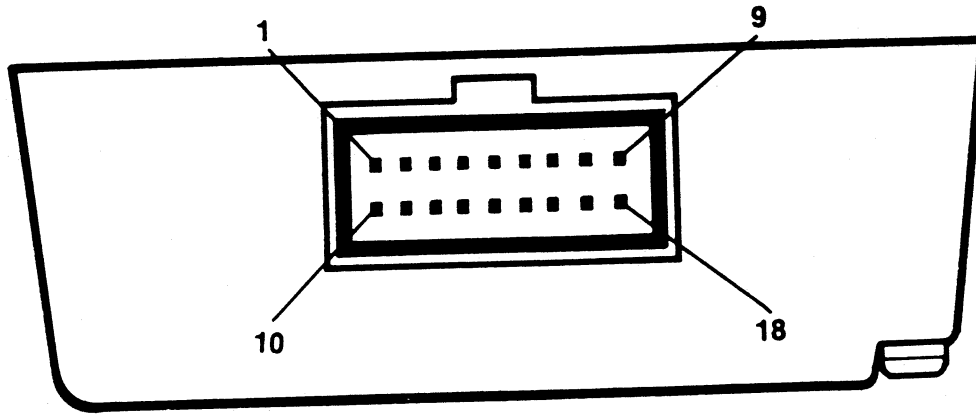

(View of Bottom of Black Control Board Cover)

18-Pin Connector

FIGURE 19

**18-Pin Mating Connector**

AMP "MODU" (18) pin MT Receptacle

AMP Part #102398-7      IDC Connector Housing

AMP Part #102536-7      Back Cover

AMP Part #102681-4      Latching Front Cover

#22 or 24 Gauge wire recommended

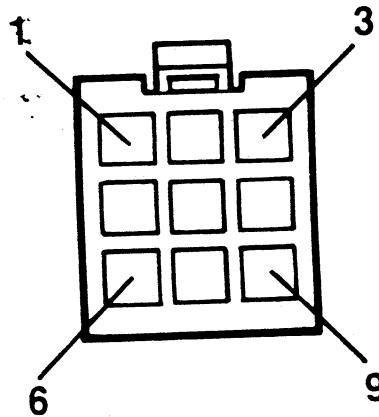

(Facing View of Connector coming off Bill Acceptor)

9-Pin Connector

FIGURE 20

**9-Pin Mating Connector**

AMP "MATE-N-LOCK" (9) pin

AMP Part #172161-1      Shell

AMP Part #170364-1      Male Pin

#22 Gauge wire recommended

## ILLUSTRATIONS

<b>Fig. 1</b>	<b>MARS ELECTRONICS® Bill Acceptor</b>	<b>p. 1</b>
<b>Fig. 2</b>	<b>Setting the Option Switches</b>	<b>p. 2</b>
<b>Fig. 3</b>	<b>Switch Functions and Sample Switch Setting</b>	<b>p. 3</b>
<b>Fig. 4</b>	<b>Seating the 9-Pin Connector</b>	<b>p. 4</b>
<b>Fig. 5</b>	<b>Seating the 18-Pin Connector</b>	<b>p. 4</b>
<b>Fig. 6</b>	<b>Bill Acceptor Dimensions</b>	<b>p. 5</b>
<b>Fig. 7</b>	<b>Removing Bills from the Magazine</b>	<b>p. 6</b>
<b>Fig. 8</b>	<b>Options Available on 18-Pin Connector</b>	<b>p. 8</b>
<b>Fig. 9</b>	<b>Lockout Diagram</b>	<b>p. 9</b>
<b>Fig. 10</b>	<b>Opening the Stacker/Magazine Assembly</b>	<b>p. 10</b>
<b>Fig. 11</b>	<b>Removing the Bezel</b>	<b>p. 11</b>
<b>Fig. 12</b>	<b>Removing the Control Board/Cover Assembly</b>	<b>p. 12</b>
<b>Fig. 13</b>	<b>Detaching the Control Board Mounting Plate</b>	<b>p. 12</b>
<b>Fig. 14</b>	<b>Separating the Bill Validator from the Stacker/Magazine Assembly</b>	<b>p. 13</b>
<b>Fig. 15</b>	<b>Opening the Bill Validator</b>	<b>p. 13</b>
<b>Fig. 16</b>	<b>Interior of Bill Validator</b>	<b>p. 14</b>
<b>Fig. 17</b>	<b>Cleaning the Bill Validator</b>	<b>p. 14</b>
<b>Fig. 18</b>	<b>Seating the Bill Validator Harnesses</b>	<b>p. 16</b>
<b>Fig. 19</b>	<b>18-Pin Connector</b>	<b>p. 18</b>
<b>Fig. 20</b>	<b>9-Pin Connector</b>	<b>p. 18</b>