



MANUAL

MAIN GAME



CHANCE GAME



BONUS GAME



Table of Contents

1. Main Menu	1 Page
2. Configuration	2 Page
• Setup	2 Page
• Coin In/Out setting	2 Page
• Output device Unused	3 Page
• Output Use HOPPER	3 Page
• Output Use Ticket Dispenser	4 Page
• Output Use Ticket Interface A	4 Page
• Output Use Ticket Interface B	4 Page
• Output Use Printer	5 Page
Printer information on Printing	6 Page
• Output rule setting	7 Page
• Game setting	9 Page
• Reset to the factory default	10 Page
3. Memory	11 Page
• View Game data	
• Initialize Game data	
4. Password	12 Page
5. Clock	13 Page
6. Function	13 Page
7. Edge Connector table	14 Page
8. Output device connection diagram	15 Page

Only “**Confirm Switch**” and **player push button** is needed to change the settings.

Name of Button	Function
DOUBLE UP	Select item Move cursor upward
TAKE SCORE	Select item Move cursor downward
BIG	Change item Up (+1) or Move cursor leftward
SMALL	Change item Down (-1) or Move cursor rightward
START	Fix as the present condition
PLAY (BET)	Exit or Fix

1. Main Menu

MAIN MENU screen is displayed by turning “ **Confirm** ” switch on.

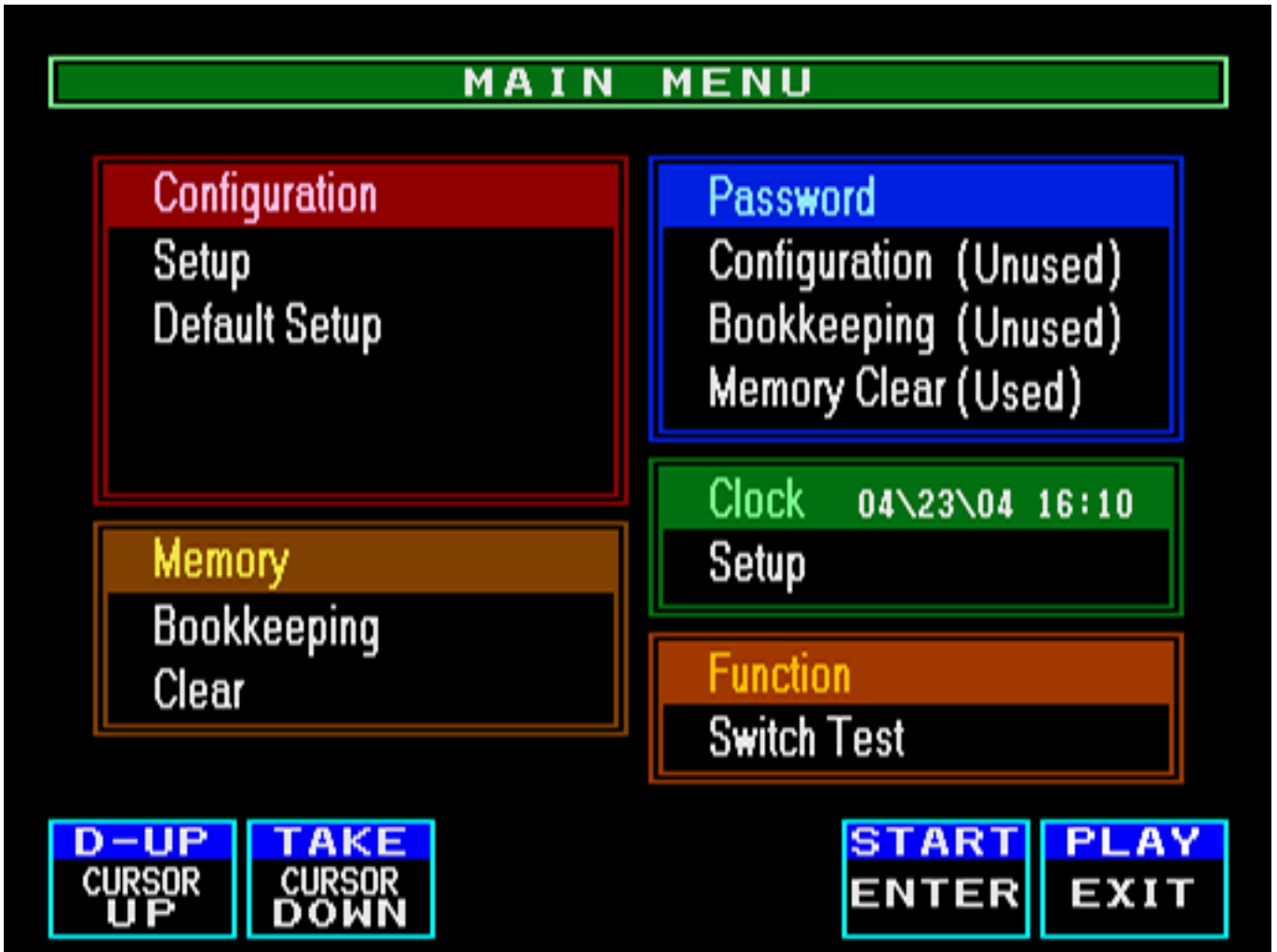

Configuration	Setup	Configuration Setup
	Default Setup	Reset to factory default
Memory	Bookkeeping	View game data (Analyze)
	Clear	Initialize game data (All clear)
Password	Configuration	Set and Change the password for game settings
	Bookkeeping	Set and Change the password for viewing game data
	Memory Clear	Set and Change the password for initializing game data
Clock	Setup	Set clock
Function	Switch Test	Switch test and screen adjustment

2. Configuration

Coin In/Out settings

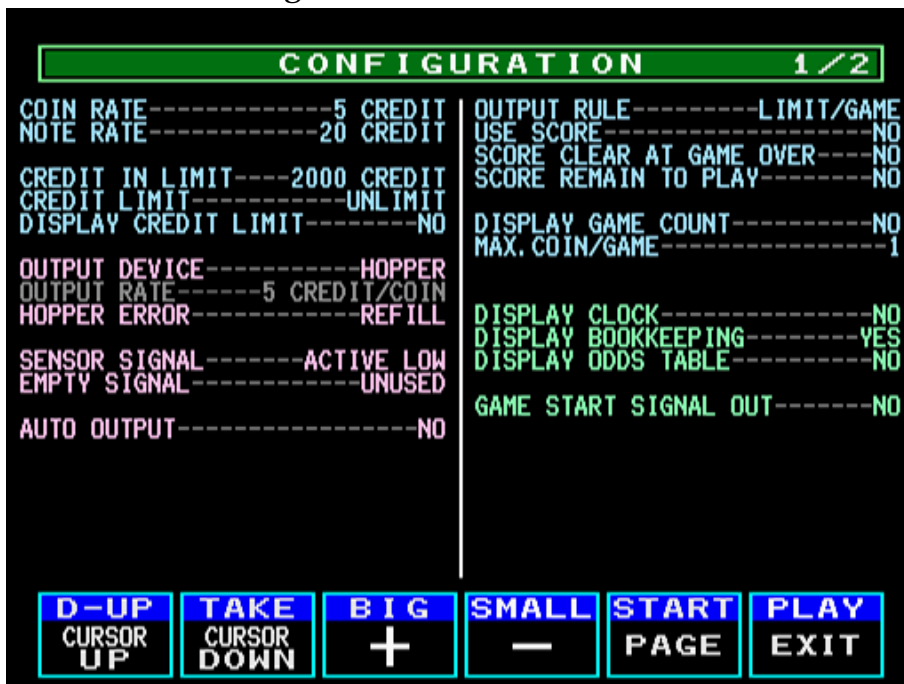

Marked in red is the default setting.

COIN RATE (Credit value per coin) **Coin Value is fixed at \$0.25**

Set Value { 1, 2, 4, **5**, 8, 10, 20, 25, 50, 100, 250, 500 }

NOTE RATE (Credit value per note (Key in))

Set Value { 2, 4, 8, 10, 16, **20**, 32, 40, 50, 80, 100, 200, 250, 400, 500, 1000, 2000, 2500, 5000 }

CREDIT IN LIMIT (Maximum credit of insertion of Coin and Note)

Set Value { UNLIMIT, 1000, **2000**, 3000, 5000, 10000, 20000 }

CREDIT LIMIT (Maximum credit to play the game)

Set Value { **UNLIMIT**, 2000, 3000, 5000, 10000, 20000, 30000, 50000 }

DISPLAY CREDIT LIMIT

Set Value { YES, **NO** }

OUTPUT DEVICE (Select output devise)

Set Value { UNUSED,
HOPPER (Coin output devise) ,
TICKET DIRECT (Ticket output devise),
INTERFACE A (Ticket output devise interface board type A),
INTERFACE B (Ticket output devise interface board type B) ,
PRINTER }

Note : Optional settings are changed depend on Output Devise.
Refer to the next page for optional settings.

2. Configuration

OUTPUT DEVICE **UNUSED**

OUTPUT RATE (Credit Value per output count)

Set Value { 1, 2, 3, 4, 5, 8, 10, 15, 20, 25, 40, 50, 75, 80, **100**, 200, 250, 400, 500, 1000, 2000, 2500, 4000, 5000 }

TRANSFER TO COLLECT (Transfer speed of credit down)

Set Value { **NOMAL**(synchronize with the meter), SLOW, FAST, INSTANT(clear instantly) }

Payout action is activated by “CREDIT DOWN (ATTENDANT)” switch, and in accordance with “OUTPUT RATE”, count up the credit down meter, and clear the credit other than a fraction.

Note: Payout rule setting in page 7 is fixed.

OUTPUT RULE (Rule for Output limit)

Set Value { fixed } **Unlimited**

OUTPUT DEVICE **HOPPER**

OUTPUT RATE (Credit Value per output coin)

Set Value { fixed } **Follow COIN RATE**

HOPPER ERROR (Handling of hopper error)

Set Value { **REFILL**, NOT REFILL }

SENDER SIGNAL (Signal level of hopper output)

Set Value { **ACTIVE LOW**(0V Level), ACTIVE HIGH(5V Level) }

EMPTY SIGNAL (Signal level of hopper empty)

Set Value { **UNUSED**, ACTIVE LOW(0V Level), ACTIVE HIGH(5V Level) }

AUTO OUTPUT (Auto output by hopper)

Set Value { YES, **NO** }

1. AUTO OUTPUT **YES**

Automatically output by each game

2. AUTO OUTPUT **NO**

Start output by “PLAYER OUTPUT” switch

3. HOPPER ERROR **REFILL** (Handle error by refill)

After refilling and turning on the power, it resumes output by “PLAYER OUTPUT” switch.

4. HOPPER ERROR **NOT REFILL** (Handle error by shortage meter.)

Count up the shortage meter by “CREDIT DOWN (ATTENDANT)” switch, then clear the credit other than a fraction.

In accordance with “OUTPUT RATE”, it outputs the amount of necessary coins, and count up output meter.

2. Configuration

OUTPUT DEVICE **TICKET DIRECT**

OUTPUT RATE ([Credit Value per output ticket](#))

Set Value { 1, 2, 3, 4, 5, 8, 10, 15, 20, 25, 40, 50, 75, 80, **100**, 200, 250, 400, 500, 1000, 2000, 2500, 4000, 5000 }

TICKET ERROR ([How to handle a ticket error](#))

Set Value { **REFILL**, NOT REFILL }

NOTCH SIGNAL ([Signal level of ticket output](#))

Set Value { **ACTIVE LOW**(0V Level), ACTIVE HIGH(5V Level) }

AUTO OUTPUT ([Auto ticket output](#))

Set Value { YES, **NO** }

1. **AUTO OUTPUT YES**

Automatically output per game

2. **AUTO OUTPUT NO**

Start output by “PLAYER OUTPUT” switch

3. **TICKET ERROR REFILL** ([Handle error by refill](#))

After turning on the power, it resumes output by “TICKET OUTPUT” switch.

4. **TICKET ERROR NOT REFILL** ([Handle error by shortage meter.](#))

Count up the shortage meter by “CREDIT DOWN (ATTENDANT)” switch, then clear the credit other than a fraction.

In accordance with “OUTPUT RATE”, it outputs the amount of necessary tickets, and count up output meter.

OUTPUT DEVICE **TICKET INTERFACE A**

OUTPUT RATE ([Credit Value per output ticket](#))

Set Value { 1, 2, 3, 4, 5, 8, 10, 15, 20, 25, 40, 50, 75, 80, **100**, 200, 250, 400, 500, 1000, 2000, 2500, 4000, 5000 }

AUTO OUTPUT ([Auto ticket output](#))

Set Value { YES, **NO** }

1. **AUTO OUTPUT YES**

Automatically output per game

2. **AUTO OUTPUT NO**

Start output by “PLAYER OUTPUT” switch

In accordance with “OUTPUT RATE”, output action sends pulse that is equivalent to necessary tickets to credit down meter.

2. Configuration

OUTPUT DEVICE **TICKET INTERFACE B**

AUTO OUTPUT ([Auto output of ticket](#))
Set Value { YES, **NO** }

1. AUTO OUTPUT **YES**
Automatically output per game.
2. AUTO OUTPUT **NO**
Start output by “PLAYER OUTPUT” switch.

Start output by “CREDIT DOWN (ATTENDANT)” switch. Output action sends pulse that is equivalent to the credit value to credit down meter, and input a fraction to “SERVICE IN”.

OUTPUT DEVICE **PRINTER**

OUTPUT RATE ([Credit Value per output ticket](#))
Set Value { 1, 2, 3, 4, 5, 8, 10, 15, 20, 25, 40, 50, 75, 80, **100**, 200, 250, 400, 500, 1000, 2000, 2500, 4000, 5000 }

PRINTER MANUFACTURE
Set Value { **ITHACA**, CITIZEN }

CREDIT PRINTED TYPE
Set Value { DOLLER, **POINT** }

AUTO OUTPUT ([Auto output of coupon](#))
Set Value { YES, **NO** }

PRINTER SETUP ([Settings for print information](#))

Operation item	INFORMATION (Location information)
	MACHINE NO (Machine number)
	VALIDATION (Coupon number)
	DISCLAIMER
	SAMPLE PRINTING

Note: Refer to the next page for how to operate printer settings.

1. AUTO OUTPUT **YES**
Automatically output the coupon by each game.
2. AUTO OUTPUT **NO**
Print out the coupon by “PLAYER OUTPUT” switch.

The printed point is calculated according to “OUTPUT RATE”, and count up the output meter.

2. Configuration

Printer information on printing

All the operation is performed by player operation panels, following the instruction on the screen.

Location Information Setting screen



Machine number Setting screen



Print coupon number Setting screen



Discrimination Setting screen



Sample printing Execution Screen



2. Configuration

Setting of Output Rule

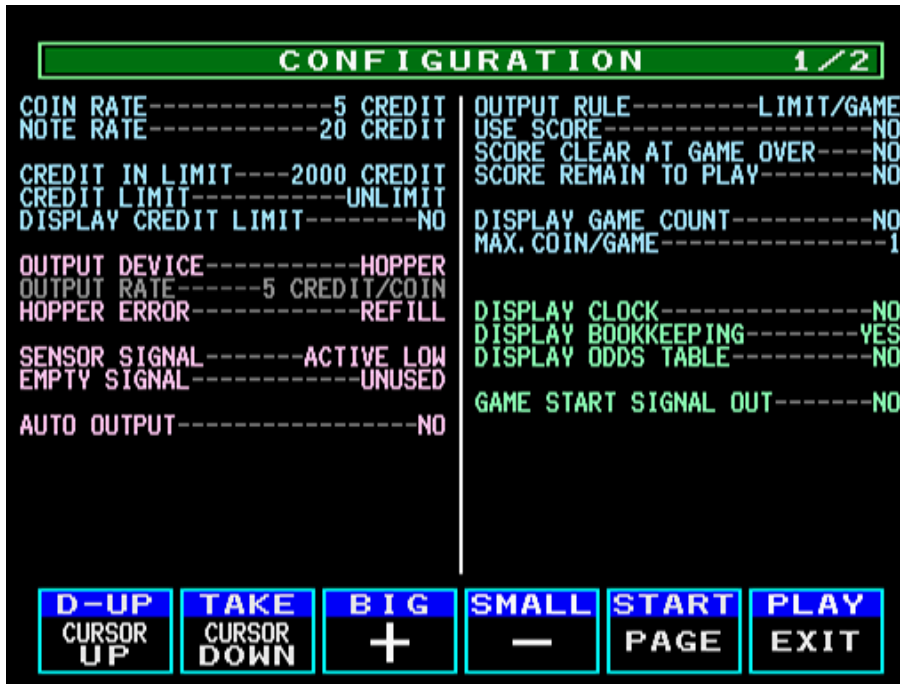

OUTPUT RULE (Rule for output limit)
 Set Value { **NO** RULE, LIMIT/GAME, 10 TIMES RULE }

Note : Option setting is changed with using output limit. Refer to the following for option settings.

OUTPUT RULE **LIMIT/GAME**

USE SCORE (Transfer the win point per game to score column)
 Set Value { **NO**, YES }

SCORE CLEAR AT GAME OVER (Clear the score column when game is over)
 Set Value { **NO**, YES }

SCORE REMAIN TO PLAY (Remained points in the score column can be used for game)
 Set Value { **NO**, YES }

DISPLAY GAME COUNT (Display the number of game count column)
 Set Value { **NO**, YES }

MAX. COIN/GAME (Maximum output points per game)
 MAX. TICKET/GAME (Same as above)
 MAX. POINT/GAME (Same as above)
 Set Value { **1**, 2, 3, 4, 5, 6, 7, 8, 9, 10 }

2. Configuration

OUTPUT RULE **10 TIMES RULE**

USE SCORE (Transfer the win point per game to score column)

Set Value { fixed } **Display**

SCORE CLEAR AT GAME OVER (Clear the score column when game is over)

Set Value { fixed } **Not Clear**

SCORE REMAIN TO PLAY (Remained points in the score column can be used for game)

Set Value { **NO**, YES }

DISPLAY GAME COUNT (Display the number of game count column)

Set Value { fixed } **Not Display**

DISPLAY CLOCK

Set Value { **NO**, YES }

DISPLAY BOOKKEEPING (Display the game data (analyze) by turning “books” switch on)

Set Value { NO, **YES** }

DISPLAY ODDS TABLE

Set Value { NO, **YES** }

GAME START SIGNAL OUT (Output pulses every time game starts)

Set Value { **NO**, YES }

2. Configuration

Game setting

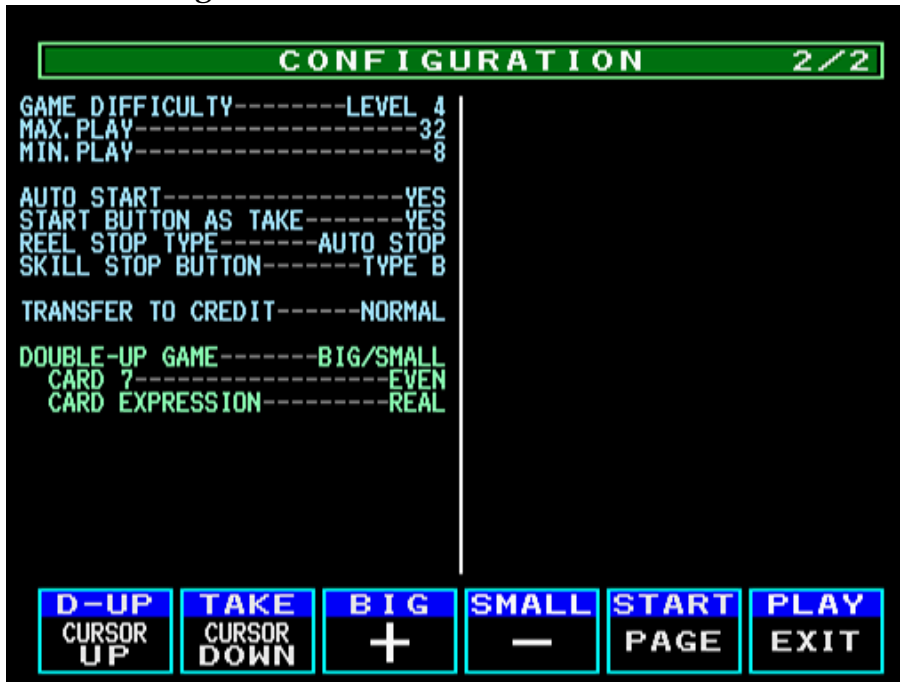

GAME DIFFICULTY ([Difficulty of game \(a dividend rate\)](#))
Set Value { LEVEL 1(easy), 2, 3, **4**, 5, 6(hard) }

MAX.PLAY ([Maximum value to play game](#))
Set Value { **32**, 40, 64, 80, 96, 120, 128, 160, 192, 200, 224, 240, 256, 280, 320, 400 }

MIN.PLAY ([Minimum value required to start game](#)) **Depend on the above item.**

MAX.PLAY 32 or 40	Set Value { 8 , 10, 16 }
MAX.PLAY 64 or 80	Set Value { 16 , 20, 32 }
MAX.PLAY 96 or 120	Set Value { 24 , 30, 48 }
MAX.PLAY 128	Set Value { 32 , 64 }
MAX.PLAY 160 or 200	Set Value { 40 , 50, 80 }
MAX.PLAY 192 or 240	Set Value { 48 , 60, 96 }
MAX.PLAY 224 or 280	Set Value { 56 , 70, 112 }
MAX.PLAY 256	Set Value { 64 , 128 }
MAX.PLAY 320 or 400	Set Value { 80 , 100, 160 }

AUTO START ([Hold pressing start button \(3 seconds\) for auto start and take score](#))
Set Value { NO, **YES** }

START BUTTON AS TAKE ([Take score by start button](#))
Set Value { NO, **YES** }

REEL STOP TYPE ([Reel Stop Action](#))
Set Value { **AUTO STOP**(Auto stop in certain span), CONTINUOUS(manual stop) }

SKILL STOP BUTTON ([Select the player operation panel](#))
Set Value { TYPE A, **TYPE B**, TYPE C, TYPE D }



2. Configuration

TRANSFER TO CREDIT ([Transfer speed of win point to credit](#))

Set Value { **NOMAL**, FAST, INSTANT }

DOUBLE-UP GAME ([Kinds of double up game](#))

Set Value { **BIG/SMALL**, RED/BLACK, NO }

NOTE: Option setting is changed depends on the selection of double up game.
Refer to the following for option settings.

DOUBLE-UP GAME **BIG/SMALL**

CARD 7 ([Victory or defeat in case the card is 7](#))

Set Value { **EVEN**, LOSE }

CARD EXPRESSION ([Pattern of card used](#))

Set Value { **REAL** (Normal pattern), SYMBOL (Abstract) }

DOUBLE-UP GAME **RED/BLACK**

CARD EXPRESSION ([Pattern of card used](#))

Set Value { **REAL** (Normal pattern), SYMBOL (Abstract) }

Reset to factory default



3. MEMORY

View game data

The screenshot shows a 'BOOKKEEPING' menu with a title bar 'BOOKKEEPING S/N 12345678'. The data is organized into three columns: 'PERMANENT', 'PERIOD', and a percentage column. The rows include 'BOX IN/OUT', 'TOTAL IN/OUT COUNT', 'HAIN IN/OUT COUNT', 'CHANCE IN/OUT COUNT', and 'BONUS OUT COUNT'. At the bottom, there are three buttons: 'TAKE RESET PERIOD', 'START PAGE', and 'PLAY EXIT'.

	PERMANENT	PERIOD	
BOX IN	15200	15200	91.6%
OUT	13930	13930	
TOTAL IN	43689	43689	
OUT	42427	42427	97.1%
COUNT	4032	4032	
HAIN IN	41977	41977	
OUT	34674	34674	81.7%
COUNT	3875	3875	
CHANCE IN	1712	1712	
OUT	1053	1053	81.7%
COUNT	112	112	
BONUS OUT	6700	6700	15.4%
COUNT	45	45	

Clear period data

This screenshot is identical to the previous one, but with a red dialog box overlaid in the center that reads 'DO YOU WANT TO RESET PERIOD?'. The buttons at the bottom are now 'D-UP EXECUTE' and 'PLAY CANCEL'.

Initialize game data

The screenshot shows a 'MEMORY CLEAR' dialog box with a title bar 'MEMORY CLEAR'. The main text reads 'DO YOU WANT TO CLEAR THE MEMORY?'. At the bottom, there are two buttons: 'D-UP EXECUTE' and 'PLAY CANCEL'.

Note: By performing this operation, all data is cleared.

4. PASSWORD

New password input screen

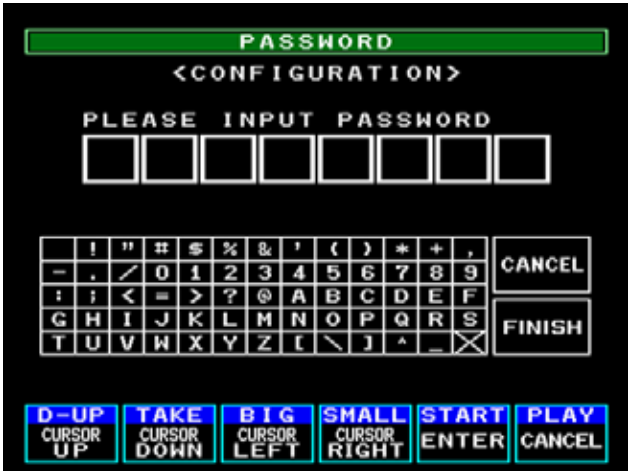

Up to 8 letters can be entered.
By overwriting with space, it is cleared and returns to the state of unused.



Message of completion of Password input

Change password screen



After entering currently used password and exiting, the new password input screen is displayed. Then enter new password.



Password input error message

5. Clock

Clock Setting screen

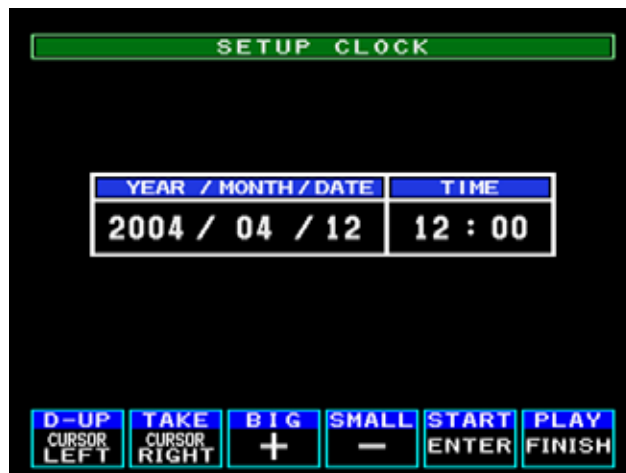

Input Year/Month/Day Hour: Minutes.
Seconds is set "00".

6. Function

Screen of switch test and screen adjustment



Each input switch can be tested. It is also used to adjust screen size of the monitor and color.

7. Edge Connector table

7 2 P i n E D G E C O N N E C T O R		
PARTS SIDE	No.	SOLDER SIDE
Video RED	1	Video GREEN
Video BLUE	2	Video SYNC
SPEAKER(+)	3	G N D
Reserve	4	Reserve
Switch Reserve	5	Switch Reserve
Switch Reserve	6	Switch Reserve
Switch TICKET OUTPUT	7	Switch Reserve
Switch TICKET NOTCH / SERVICE IN	8	Switch Reserve
Switch Player START Button	9	Switch Reserve
Switch Player SMALL / ODDS Button	1 0	Switch Reserve
Switch Player PLAY(BET) Button	1 1	Switch Reserve
Switch Player TAKE-SCORE Button	1 2	Switch Reserve
Switch Player DOUBLE-UP Button	1 3	Switch Reserve
Switch Reserve	1 4	Switch Reserve
Switch Reserve	1 5	Switch Reserve
Switch Player BIG Button	1 6	Switch Reserve
Switch Reserve	1 7	Switch Reserve
Switch COIN IN	1 8	Switch NOTE IN
Switch COIN IN(*)	1 9	Switch COIN IN(*)
Switch BOOKKEEPING	2 0	Switch CONFIRM
Switch Player OUTPUT (Coupon / Hopper)	2 1	Switch CREDIT DOWN
Switch HOPPER EMPTY	2 2	Switch HOPPER SENSOR
Meter COIN IN	2 3	Blocker COIN IN
Meter NOTE IN	2 4	Blocker
Output Reserve	2 5	Blocker
Output GAME STRAT SIGNAL	2 6	Blocker
Meter OUTPUT (Ticket / Coupon / Hopper)	2 7	Meter LACK OF HOPPER
Meter CREDIT DOWN	2 8	Output HOPPER DRIVE
Lamp Player START	2 9	Lamp Reserve
Lamp Player SMALL / ODDS	3 0	Lamp Reserve
Lamp Player PLAY(BET)	3 1	Lamp Reserve
Lamp Player TAKE-SCORE	3 2	Lamp Reserve
Lamp Player DOUBLE-UP	3 3	Lamp Reserve
Lamp Player BIG	3 4	Lamp Reserve
Switch Reserve	3 5	Switch Reserve
G N D	3 6	G N D

Note: Coin in is common.

2 0 P i n E D G E C O N N E C T O R		
PARTS SIDE	No.	SOLDER SIDE
G N D	1	G N D
G N D	2	G N D
+ 5V	3	+ 5V
+ 5V	4	+ 5V
+12V	5	+12V
Meter +V	6	COIN BLOCKER+V
TICKET ENABLE	7	*AC input is prohibited.
	8	
G N D	9	G N D
G N D	1 0	G N D

8. Output device connection diagram

Output Device Hopper

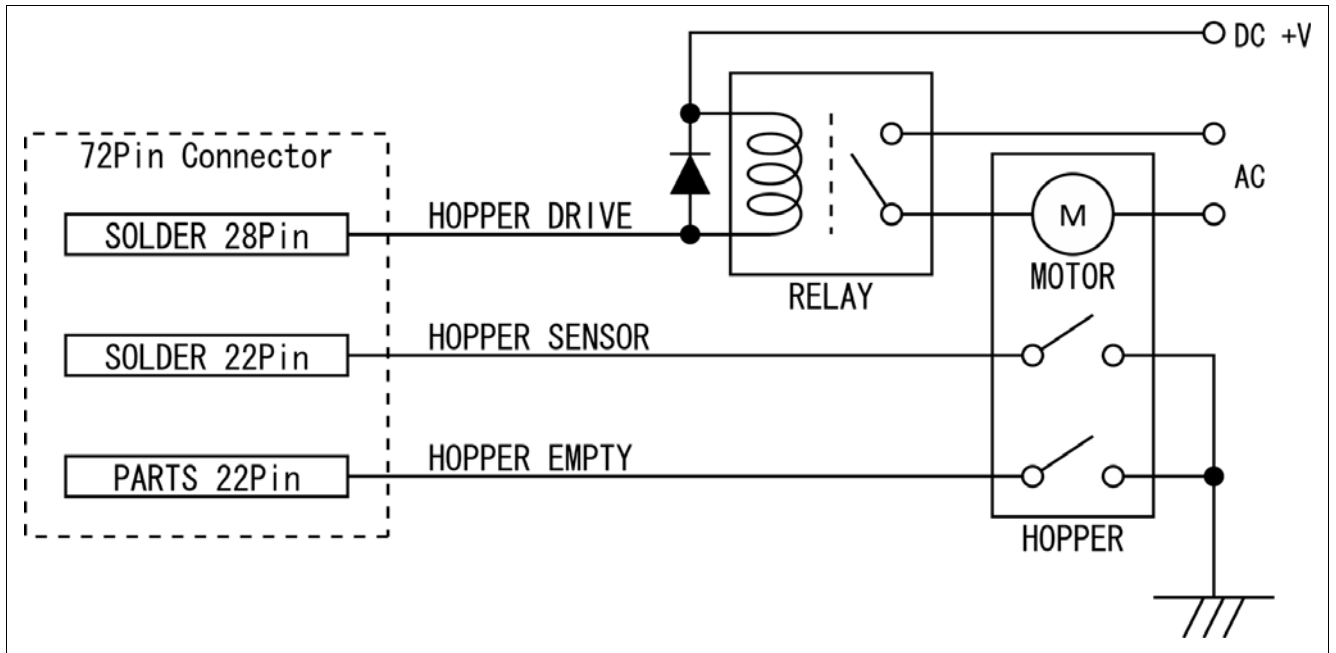

Output Device Ticket Dispenser

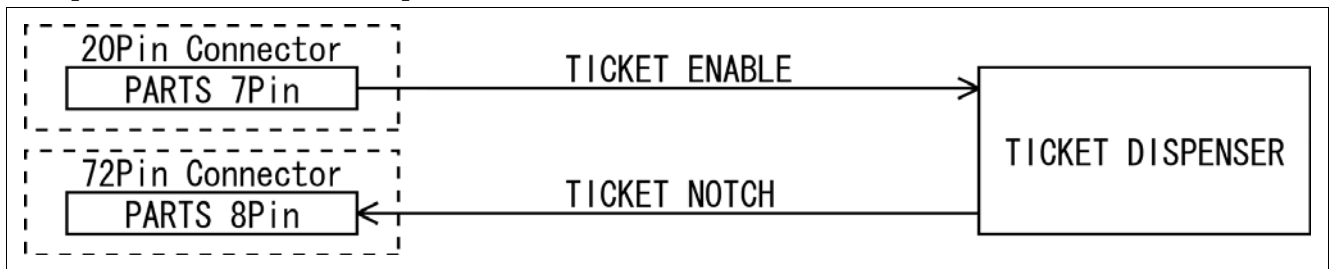

Output Device Ticket Interface A

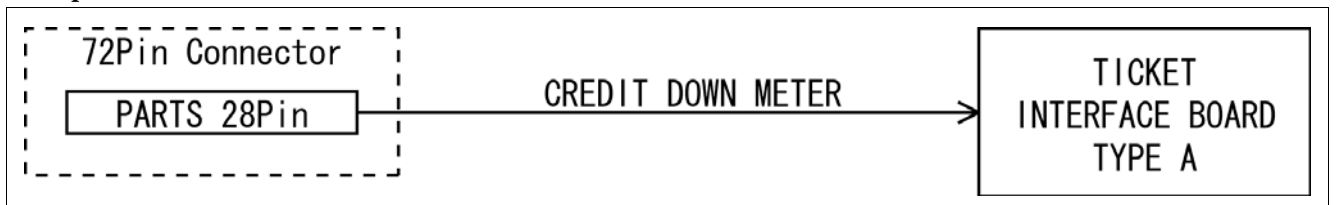

Output Device Ticket Dispenser B

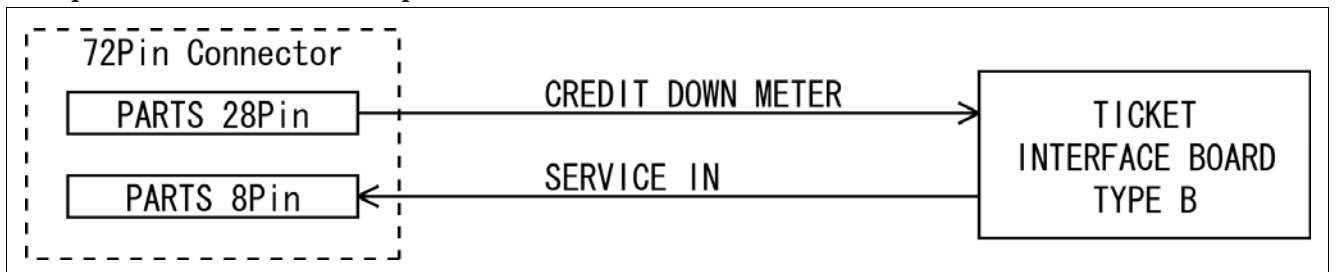

DYNA[®]

DYNA Co., Ltd.

<http://www.dynagame.co.jp/>